

ACTIVE FORCE CONTROL WITH INPUT SHAPING TECHNIQUE FOR A SUSPENSION SYSTEM

Mohd Zarhamdy Md Zain¹,
Musa Mailah,
G. Priyandoko

Faculty of Mechanical Engineering,
Universiti Teknologi Malaysia,
81310 Skudai, Johor, Malaysia.

ABSTRACT

This paper describes an approach to investigate and develop a hybrid control scheme for vibration suppression of a vehicle suspension system. Initially, an active force control (AFC) scheme is developed for the motion control of the system. This is then extended to incorporate a feed forward controller based on an input shaping (IS) technique for the control of vibration of the suspension system that could in turn lead to the enhancement of the riding performance of the vehicle. Simulation results of the response of the suspension system with the proposed control scheme are presented in time and frequency domains. The performance of the hybrid control scheme with AFC and IS control are particularly assessed in terms of the level of vibration reduction.

Keywords : *Active force control (AFC), input shaping (IS), vibration, suspension system.*

1.0 INTRODUCTION

For many years, automobile suspension has been consisted of a coil or leaf spring in parallel with viscous damper. The control of automobile suspensions is currently of great interest in both the academic and industrial fields. Suspension design requires a compromise between the passenger comfort and good handling vehicle. To provide a good ride comfort, the suspension should be soft enough, but whereas good road holding requires stiff suspension. A good vehicle suspension should be able to minimize the vertical displacement and the acceleration of the body. However, in order to increase the passenger comfort, the sprung mass displacement needs to be minimized.

In the conventional passive suspension system, the mass-spring-damper parameters are generally fixed, and they are chosen based on the design requirements of the vehicles. The suspension has the ability to store energy in the spring and to dissipate it through the damper. When a spring supports a load, it will compress until the force produced by the compression is equal to the load

¹ Corresponding author: E-mail: zarhamdy@fkm.utm.my

force. If some other forces then disturb the load, then the load will oscillate up and down around its original position for some time.

Passive suspension utilizing mechanical springs and dampers is known to have the limitations of vibration isolation and lack of attitude control of the vehicle body. To solve these problems, many researchers have studied various active and semi-active suspensions both theoretically and experimentally. In semi active suspension systems, it still uses springs as the main form of support; however the dampers can be controlled. A semi active suspension has the ability to change the damping characteristics of the shock absorbers without using any actuators. Active suspension differs from the conventional passive suspension in its ability to inject energy into the system. In an active suspension system, an actuator is attached in parallel with both a spring and a shock absorber. To achieve the desired performance, actuator should generate the desired force in any direction, regardless of the relative velocity across it. The ability to control the energy from external source according to the environment provides better performance of suspension system. For this reason, the active suspension is widely investigated [1-5].

Huang and Lin [6] used self-organizing (self-tuning) fuzzy controller to control the position and acceleration oscillation amplitude of the sprung mass due to the rough road variation. The experimental results show that this controller effectively suppresses the vibration amplitude and reduce the acceleration of the sprung mass for improving the vehicle ride comfort. Son and Isik [7] showed that the performance of optimal control and fuzzy control are both much better than of the passive suspension for all different road conditions. The fuzzy logic control is slightly better than the optimal control in all conditions. In works by D'Amato and Viassolo [8], it is the goal of the study to minimize vertical car body acceleration and to avoid hitting suspension limits. A controller consisting of two control loops is proposed to attain this goal. The inner loop controls a nonlinear hydraulic actuator to achieve tracking of a desired actuation force. The outer loop implements a fuzzy logic controller to provide the desired actuation force. Controller parameters are computed by genetic algorithm (GA) based optimization. The methodology proved effective when applied to a quarter car model of suspension system.

Kuo and Li [9] employed fuzzy PI and PD type controllers that are combined to cope with the different road conditions. By using the merit of GA's, the optimal decision making rules for both type controllers are constructed [9]. The results demonstrated that the fusion of GA's and fuzzy controller for an active suspension can provide passenger much more ride comfort. Another form of controller has been proposed using active force control (AFC) strategy with adaptive fuzzy logic to robustly control the suspension system of a quarter car model as described in Mailah and Priyandoko [10]. Simulation study of the system proves that the control algorithms used are simple, computationally less intensive and can be implemented in real-time. It is shown that the proposed system performs excellently even in the presence of the introduced disturbances and given road conditions.

As an extension to the above, it is the objective of this research study to design a controller of a vehicle suspension system via a simulation study for reducing the

vertical body displacement, suspension deflection, tyre deflection and body acceleration using a hybrid control scheme known as Active Force Control with Input Shaping (AFCIS) strategy that can further consolidate the performance of the system.

2.0 DYNAMIC MODEL OF AN ACTIVE SUSPENSION

The model of the quarter car active suspension system used is shown in Figure 1. The quarter car is presented by a two degree-of-freedom (DOF) model. The equations of motion for this system are given as [6]:

$$\begin{aligned} m_s \ddot{z}_s &= -k_s(z_s - z_u) - b_s(\dot{z}_s - \dot{z}_u) + f_a \\ m_u \ddot{z}_u &= k_s(z_s - z_u) + b_s(\dot{z}_s - \dot{z}_u) - k_t(z_u - z_r) - f_a \end{aligned} \quad (1)$$

where m_s , m_u , b_s , k_s , k_t , f_a , z_s , z_u , z_r , $z_s - z_u$, $z_u - z_r$, \dot{z}_s , \dot{z}_u are mass sprung, mass unsprung, damping coefficient, spring stiffness coefficient, tyre stiffness coefficient, active force, respectively, displacement of the car body, displacement of wheel (unsprung), displacement of road, suspension deflection, tyre deflection, velocity of car body and velocity of wheel, respectively.

By assuming that the suspension spring coefficient and tyre stiffness are linear in their operation ranges, the tyre does not leave the ground. The displacements of both the body and wheel can be measured from the static equilibrium point.

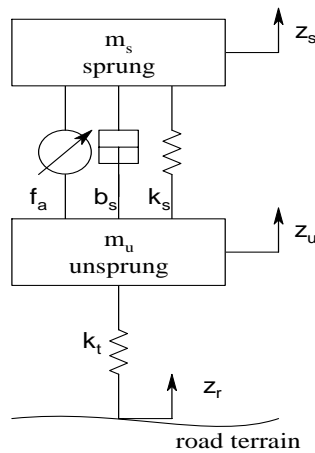

Figure 1: A quarter car active suspension model

3.0 DYNAMIC MODEL OF A HYDRAULIC ACTUATOR

Figure 2 depicts a schematic diagram of a translational double acting hydraulic actuator driven by a three-land four-way spool valve. An actuator is assumed to be placed between the sprung and unsprung masses and can exert a force f_a in between m_s and m_u .

The hydraulic actuator is assumed to consist of a spool valve (servo valve) and a hydraulic cylinder. P_s and P_r are the supply and return pressure going into and

out of the spool valve, respectively, x_{sp} is spool valve position, P_u and P_l are the oil pressure in the upper and lower cylinder chambers respectively and x_w-x_c is the hydraulic piston displacement. The differential equation governing the dynamics of the actuator is given in [6] as follows:

$$\frac{V_t}{4\beta} \dot{P}_L = Q_L - C_{tm}P_L - A(\dot{z}_s - \dot{z}_u) \quad (2)$$

where V_t , β_e , A , C_{tm} is total actuator volume, effective bulk modulus, actuator ram area and coefficient of total leakage due to pressure, respectively. Using the equation for hydraulic fluid flow through an orifice, the relationship between spool valve displacement x_v and the total flow Q_L is given as [6]:

$$Q_L = C_d W x_v \sqrt{\frac{P_s - \text{sgn}(x_v) P_L}{\rho}} \quad (3)$$

where C_d , W , C_{tm} is discharge coefficient, spool valve area gradient and total leakage coefficient, respectively.

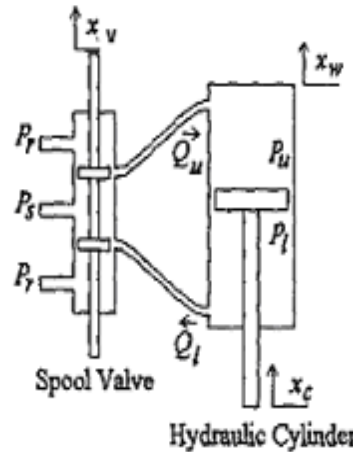

Figure 2: A double acting hydraulic cylinder

4.0 CONTROL SCHEMES

In this section, the development of the control schemes for the vibration suppression of the suspension system is described. It follows a set of procedure in which the active force control (AFC) with the proportional-derivative (PD) element was first designed. This includes the appropriate tuning of the PD gains through a heuristic method (trial-and-error) and also the acquisition of the main AFC parameter, namely, the estimated mass. The proposed control scheme was then applied to the dynamics of the suspension system with the application of the disturbance models (road profiles) and specific reference input. This is then extended to incorporate an input shaping (IS) scheme for further compensation of the vibration that occurs in the system. The performance measurement is based on

the ability of the proposed active suspension system to suppress the vibration level of the system subject to a number of road profiles as the input disturbances to the system. Also, good performance of the system is indicated by the reduction of the following parameters:

- i. sprung mass (body) displacement and acceleration
- ii. tyre deflection
- iii. suspension deflection

4.1 Active Force Control

Hewit and Burdett [11] proposed a strategy called active force control (AFC) which is an effective method that has been established to facilitate robust motion control of dynamical systems in the presence of disturbances, parametric uncertainties and changes that are commonly prevalent in the real-world environment. Mailah *et al.* [12-14] extended the usefulness of the method by introducing intelligent mechanisms to approximate the mass or inertia matrix of the dynamic system to trigger the compensation effect of the controller.

The AFC method is a technique that relies on the appropriate estimation of the inertial or mass parameters of the dynamic system and the measurements of the acceleration and force signals induced by the system if practical implementation is ever considered. For theoretical simulation, it is normal that perfect modelling of the sensors is assumed and that noises in the sensors are totally neglected. In AFC, it is shown that the system subjected to a number of disturbances remains stable and robust via the compensating action of the control strategy. A more detailed description on the mathematical treatment related to the derivation of important equations and stability criterion, can be found in [11, 15]. For brevity, the underlying concept of AFC applied to a dynamic rotational system is presented with reference to Figure 3.

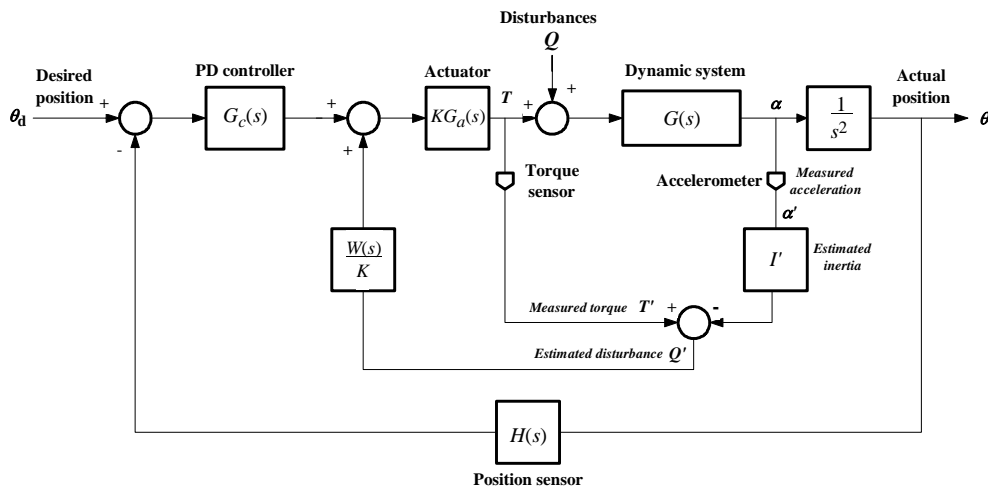

Figure 3. A schematic diagram of an AFC scheme

The notations used in Figure 3 are as follows:

θ_d	:	desired joint position
θ	:	actual joint position
K	:	constant gain
$G(s)$:	dynamic system transfer function
$G_a(s)$:	Actuator transfer function
$G_c(s)$:	Outer loop controller
$H(s)$:	Sensor transfer function
$W(s)$:	Weighting function
Q	:	Disturbances
T	:	applied torque
I	:	mass moment of inertia
α	:	angular acceleration

The computed variable Q' often known as the estimated disturbance is obtained by considering the following expression:

$$Q' = T' - I' \alpha' \quad (4)$$

where the superscript ' denotes a measured, computed or estimated quantity. T' can be readily measured by means of a torque sensor and α' using an accelerometer. I' may be obtained by assuming a perfect model, crude approximation or intelligent methods [12]. Q' is then passed through a weighting function $W(s)$ to give the ultimate AFC signal command to be embedded with an outer control loop. This creates a two degree-of-freedom controller that could provide excellent overall system performance provided that the measurement and estimated parameters were appropriately acquired. The outer control loop can be a proportional-integral-derivative (PID) controller, resolved motion acceleration controller (RMAC), intelligent controller or others deemed suitable.

It is apparent that a suitable choice of $W(s)$ needs to be obtained that can cause the output to be made invariant with respect to the disturbances Q such that:

$$G_a(s)W(s) = 1 \quad (5)$$

In other words, if $W(s)$ is chosen as the inverse of $G_a(s)$ with $Q' = Q$, then perfect force control should be possible [11]. A set of outer control loop control is applied to the above open loop system, by first generating the world coordinate error vector, $e = (\theta_d - \theta)$ which would then be processed through a controller function, $G_c(s)$, typically a classic PD controller that maybe represented by:

$$u(s) = G_c(s)e(s) = (K_p + K_d s)e(s) \quad (6)$$

Where

$u(s)$:	control signal
$e(s)$:	error signal

K_p : proportional gain
 K_d : derivative gain

It is common that the gains can be acquired using techniques such as *Ziegler-Nichols* tuning method, root locus or pole placement methods apart from heuristic means. The main computational burden in AFC is the multiplication of the estimated inertial parameter with the angular acceleration of the dynamic component before being fed into the AFC feed-forward loop. Researchers in [12, 16-17] have demonstrated the effectiveness of the AFC scheme applied to rigid robot arms. Mailah *et al.* [10] have equally shown a robust intelligent AFC method that is capable of controlling a vehicle suspension system and effectively suppressing the introduced disturbances. In the study, most of the designed parameters used for the AFC section are based on works done in [10].

4.2 Input Shaping

The method of input shaping involves convolving a desired command with a sequence of impulses. The design objectives are to determine the amplitude and time location of the impulses. A brief derivation is given below with details can be found in [18]. A vibratory system of any order can be modeled as a superposition of second order systems with transfer function:

$$G(s) = \frac{\omega^2}{s^2 + 2\xi\omega s + \omega^2} \quad (7)$$

where ω is the natural frequency and ξ is the damping ratio of the system. Thus, the impulse response of the system can be obtained as:

$$y(t) = \frac{A\omega}{\sqrt{1-\xi^2}} e^{-\xi\omega(t-t_0)} \sin(\omega\sqrt{1-\xi^2}(t-t_0)) \quad (8)$$

where A and t_0 are the amplitude and time of the impulse respectively. Further, the response to a sequence of impulses can be obtained by superposition of the impulse responses. Thus, for N impulses, with $\omega_d = \omega(\sqrt{1-\xi^2})$, the impulse response can be expressed as:

$$y(t) = M \sin(\omega_d t + \beta) \quad (9)$$

where

$$M = \sqrt{\left(\sum_{i=1}^N B_i \cos \phi_i\right)^2 + \left(\sum_{i=1}^N B_i \sin \phi_i\right)^2}, \quad B_i = \frac{A_i \omega}{\sqrt{1-\xi^2}} e^{-\xi\omega(t-t_0)} \text{ and} \quad (10)$$

$$\phi_i = \omega_d t_i$$

A_i and t_i are the magnitudes and times at which the impulses occur.

The residual vibration amplitude of the impulse response can be obtained by evaluating the response at the time of the last impulse, t_N as:

$$V = \frac{\omega}{\sqrt{1-\xi^2}} e^{-\xi\omega(t_N)} \sqrt{(C(\omega, \xi))^2 + (S(\omega, \xi))^2} \quad (11)$$

where

$$C(\omega, \xi) = \sum_{i=1}^N A_i e^{-\xi\omega t_i} \cos(\omega_d t_i) \quad (12)$$

and

$$S(\omega, \xi) = \sum_{i=1}^N A_i e^{-\xi\omega t_i} \sin(\omega_d t_i) \quad (13)$$

In order to achieve zero vibration after the input has ended, it is required that $C(\omega, \xi)$ and $S(\omega, \xi)$ in equation (11) are independently zero. Furthermore, to ensure that the shaped command input produces the same rigid body motions as the unshaped command, it is required that the sum of impulse amplitudes $\sum_{i=1}^N A_i = 1$. To avoid delay, the first impulse is selected at time 0. The

simplest constraint is zero vibration at expected frequency and damping of vibration using a two-impulse sequence. Hence by setting equation (11) to zero and solving yields a two-impulse sequence with parameters as:

$$\begin{aligned} t_1 &= 0, & t_2 &= \frac{\pi}{\omega_d}, \\ A_1 &= \frac{1}{1+K}, & A_2 &= \frac{K}{1+K} \end{aligned} \quad (14)$$

Where

$$K = e^{-\frac{\xi\pi}{\sqrt{1-\xi^2}}} \quad (15)$$

The robustness of the input shaper to error in natural frequencies of the system can be increased by setting $\frac{dV}{d\omega} = 0$, where $\frac{dV}{d\omega}$ is the rate of change of V with respect to ω . Setting the derivative to zero is equivalent to setting small changes in vibration for changes in the natural frequency. Thus, additional constraints are added into the equation, which after solving yields a three-impulse sequence with parameters as:

$$t_1 = 0, \quad t_2 = \frac{\pi}{\omega_d}, \quad t_3 = 2t_2,$$

$$A_1 = \frac{1}{1+2K+K^2}, \quad A_2 = \frac{2K}{1+2K+K^2}, \quad A_3 = \frac{K^2}{1+2K+K^2} \quad (16)$$

where K is as in equation (14). The robustness of the input shaper can further be increased by taking and solving the second derivative of the vibration in equation (11). Similarly, this yields a four-impulse sequence with parameters as:

$$t_1 = 0, \quad t_2 = \frac{\pi}{\omega_d}, \quad t_3 = 2t_2, \quad t_4 = 3t_2,$$

$$A_1 = \frac{1}{1+3K+3K^2+K^3}, \quad A_2 = \frac{3K}{1+3K+3K^2+K^3},$$

$$A_3 = \frac{3K^2}{1+3K+3K^2+K^3}, \quad A_4 = \frac{K^3}{1+3K+3K^2+K^3}. \quad (11)$$

where K is as in equation (14).

To handle higher vibration modes, an impulse sequence for each vibration mode can be designed independently. Then the impulse sequences can be convoluted together to form a sequence of impulses that attenuates vibration at higher modes. For any vibratory system, the vibration reduction can be accomplished by convolving any desired system input with the impulse sequence. This yields a shaped input that drives the system to a desired location without vibration. By incorporating the input shaping feature into the AFC scheme, it results in the combined AFC and input shaping control structure shown in Figure 4.

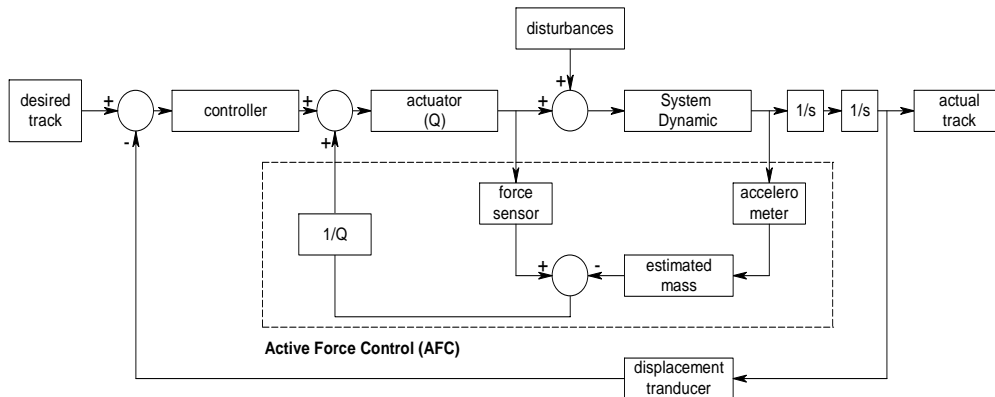

Figure 4: A schematic diagram of AFC strategy with input shaper

5.0 RESULTS AND DISCUSSION

In this section, the proposed control schemes are implemented and tested within simulation environment of the suspension system and the corresponding results are presented. The suspension system is required to follow a road profile as shown in Figure 5. It is considered as a form of ‘disturbance’ to the system. The output of the hydraulic actuator then becomes the inputs of system dynamics within the AFC control loop. The AFC scheme has two inputs, namely the active force hydraulic actuator and body acceleration components. The estimation of mass needed by AFC loop is the main factor which contribute to the effectiveness of the control scheme. In this simulation, in order to estimate the mass needed to feed the forward control loops, neural network strategy is used.

The simulation works were performed with the parameters and conditions explained in [10] to demonstrate that sprung mass (body) displacement and acceleration, suspension deflection, tyre deflection when the car hits the bump. The parameters used in the study are listed as follows:

$$\begin{array}{lll}
 m_s = 290 \text{ kg} & \beta = 1.00 & k_v = 0.0157 \text{ m/A} \\
 m_u = 59 \text{ kg} & \alpha = 4.515e^{12} \text{ N/m}^5 & \tau = 0.0046 \text{ s} \\
 k_s = 16,812 \text{ N/m} & \gamma = 1.545e^9 \text{ N/(m}^{5/2} \text{ kg}^{1/2}) & \\
 b_s = 1\,000 \text{ N/m/s} & P_s = 1500 \text{ Psi (10342500 Pa)} & \\
 k_u = 190\,000 \text{ N/m} & A = 3.35e^{-4} \text{ m}^2 &
 \end{array}$$

In this study, the limit suspension deflection is set to ± 6 cm.

The results for simulations described are given in Figures 6(i) and 6(ii). In each case, the dotted line describes the response of the AFC without input shaping (IS), the dashed line shows the response of the AFCIS with 2-impulses and the solid line shows the response of the AFCIS with 4-impulses in suspension system. It is obvious that the AFCIS with 4-impulses produces the best performance than its counterparts in compensating the introduced disturbances. This implies that the system is more robust and effective.

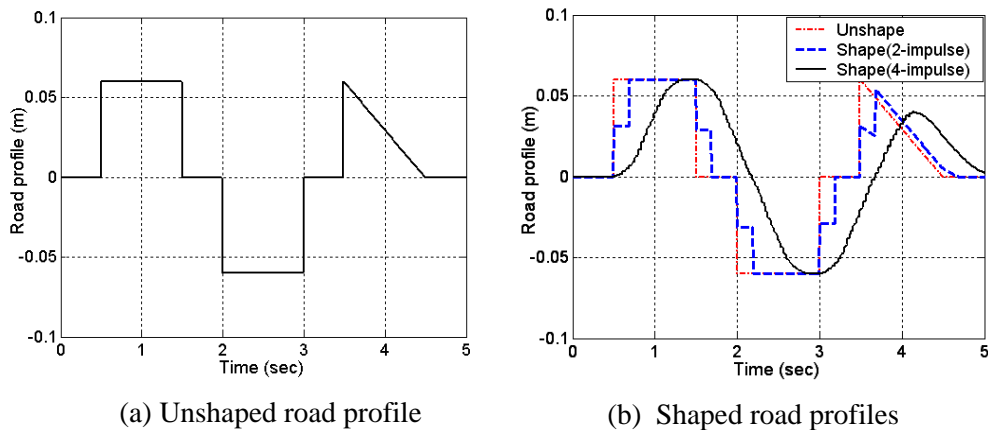
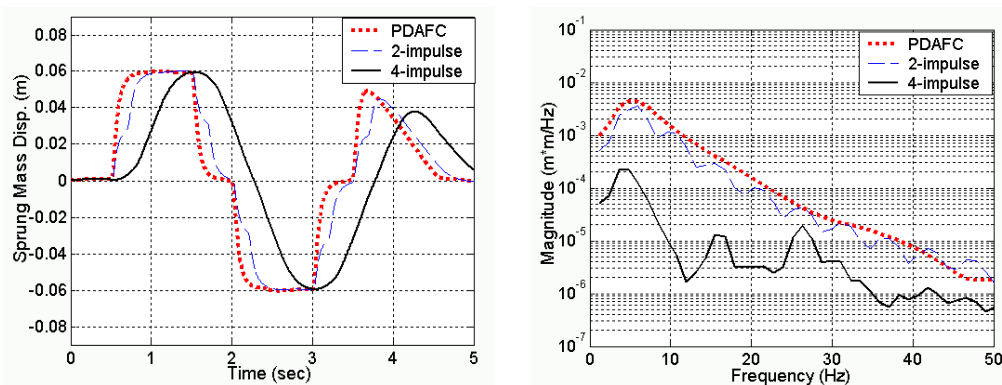
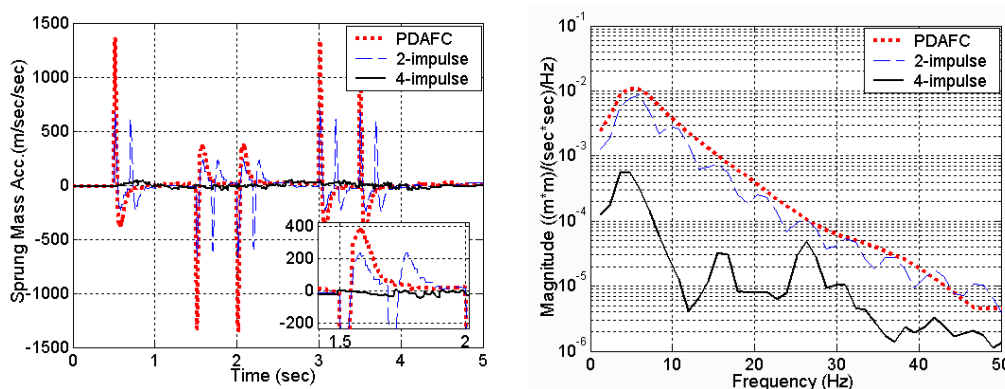

Figure 5: Road profiles

To assess the vibration reduction in the system in the frequency domain, power spectral density (SD) of response at suspension was obtained. Thus, the first modes of vibration of the system are considered as these dominantly characterize the behaviour of the suspension system. The corresponding responses of the suspension system AFCIS are shown in Figures 6(i) and 6(ii). It is noted that the proposed AFCIS with various impulses are capable of reducing the system vibration performance. The vibration of the system settled within less than 2 sec which is much less than that achieved with AFC control. Moreover, the AFCIS with 4-impulses is found to be able to handle vibration of the suspension system. This is further evidenced in Figure 9 which shows a summary of the level of vibration reduction achieved at the resonance mode using AFCIS as compared to AFC without IS scheme. For the first mode, which is the most dominant mode, reduction of 2 dB in IS 2-impulses and 26 dB in IS 4-impulses were achieved for the suspension system respectively.



(a) Sprung mass displacement



(b) Sprung mass acceleration

Figure 6(i): System response of the AFCIS control scheme (with different sets of impulses) compared to PDAFC

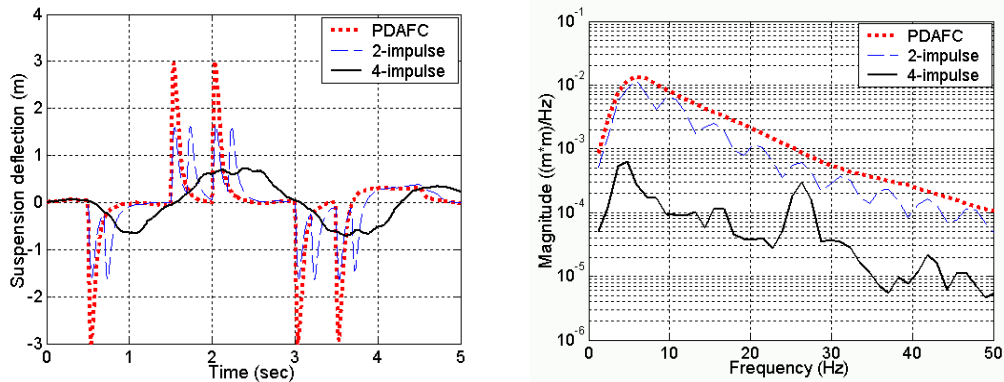

(a) Suspension deflection

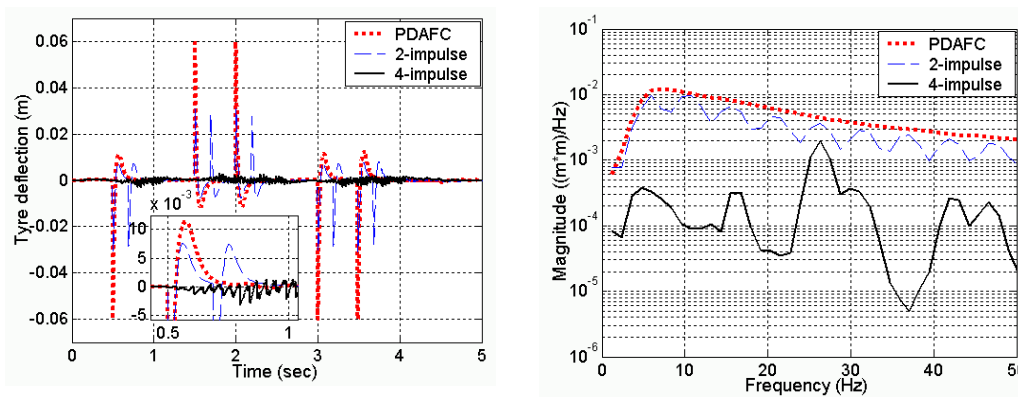

(b) Tyre deflection

Figure 6(ii): System response of the AFCIS control scheme (with different sets of impulses) compared to PDAFC

6.0 CONCLUSION

The development of hybrid control schemes for vibration suppression of a suspension system has been presented. The control schemes have been developed on the basis of AFC and input shaping techniques. The control schemes have been implemented and tested within simulation environment of a suspension system. The performances of the control schemes have been evaluated in terms of vibration suppression at the resonance modes of the suspension. Acceptable vibration suppression has been achieved with both control strategies. A comparative assessment of the control techniques has shown that AFCIS with 4-impulses scheme results in better performance than the pure AFC control in respect of vibration suppression of the suspension.

REFERENCES

1. M.V.C. Rao, V. Prahlad, 1997. A Tunable Fuzzy Logic Controller for Vehicle Active Suspension Systems, *Fuzzy Set and System*.
2. Chantranuwathana, S.; Peng, H., 2004. Adaptive Robust Force Control for Vehicle Active Suspensions, *International Journal of Adaptive Control and Signal Processing*, Vol. 18, pp. 83-102.
3. A. Alleyne, R. Liu, H. Wright, 1998. On the Limitations of Force Tracking Control for Hydraulic Active Suspensions”, *Proc. Of the American Control Conference*, Philadelphia, Pennsylvania, June.
4. A.J. Barr, J.I Ray, 1996. Control of an Active Suspension using Fuzzy Logic, *Proceedings of the Fifth IEEE International Conference on Fuzzy Systems*, Vol. 1, pp. 42 – 48, vol.1, 8-11 Sept.
5. J. Campos, F.L. Lewis, L. Davis, S. Ikenaga, 2000. Backstepping Based Fuzzy Control of Active Vehicle Suspension Systems, *American Control Conference, 2000*. Proceedings of the 2000, Volume: 6, 28-30 June.
6. Huang, S.J., Lin, W.C., 2003. A Self Organizing Fuzzy Controller for an Active Suspension System, *Journal of Vibration and Control*, vol. 9, no. 9.
7. Son, S., Isik, C., 1996. Application of Fuzzy Logic Control to an Automotive Action Suspension System, *Proc. of the Fifth Int. Conf. on Fuzzy Systems*, pp. 548-553
8. D’Amato, F., Viassolo, D.E., 2000. Fuzzy Control for Active Suspensions, *Mechatronics*, vol.10, pp. 897-920.
9. Kuo, Y.P., Li, T.S., 1999. GA-based Fuzzy PI/PD Controller for Automotive Active Suspension System, *IEEE Transactions on Industrial Electronics*, Vol. 46, No. 6, December.
10. Mailah, M., Priyandoko, G., 2007. Simulation of A Suspension System With Adaptive Fuzzy Active Force Control, *International Journal on Simulation Modelling*, Vol. 6, No.1, pp. 25-36
11. Hewit, J. R. and Burdess, J. S., 1981. Fast Dynamic Decoupled Control for Robotics using Active Force Control. *Trans. Mechanism and Machine Theory*, **16**(5), pp. 535-542.
12. Mailah, M., 1998. *Intelligent Active Force Control of a Rigid Robot Arm Using Neural Network and Iterative Learning Algorithms*. University of Dundee, UK: Ph.D Thesis.
13. S.B.Hussein, A.M.S. Zalzal, H. Jamaluddin, M. Mailah, 2000. An Evolutionary Neural Network Controller for Intelligent Active Force Control, *Evolutionary Design and Manufacture*, Ed. I.C. Parmee, Springer Verlag, London, pp 352-362.
14. Mailah, M., Pitowarno, E., Jamaluddin, H., 2005. Robust Motion Control for Mobile Manipulator Using Resolved Acceleration and Proportional-Integral Active Force Control, *International Journal of Advanced Robotic Systems*, Vol. 2, No. 2, pp. 125-134.
15. Burdess, J. S., Hewit, J. R., 1986. An Active Method for the Control of Mechanical Systems in the Presence of Unmeasurable Forcing, *Trans. Mechanism and Machine Theory*, vol. 21, no. 3, pp. 393-400.

16. Mailah, M., Hewit, J.R., Meeran, S., 1996. Active Force Control Applied to A Rigid Robot Arm, *Jurnal Mekanikal*, Vol.2, No.2, pp. 52-68.
17. Pitowarno, E., Mailah, M., Jamaluddin, H., 2002. Knowledge-Based Trajectory Error Pattern Method Applied to An Active Force Control Scheme, *International Journal of Engineering and Technology*, Vol. 2, No.1, pp. 1-15.
18. M.Z. Mohd Zain, M.O. Tokhi and Z. Mohamed, 2006. Hybrid learning control schemes with input shaping of a flexible manipulator system, *Mechatronics*, **16**, pp. 209-219.