

MOTION CONTROL OF NONHOLONOMIC WHEELED MOBILE ROBOT IN A STRUCTURED LAYOUT

Tang Howe Hing
Musa Mailah

Department of Applied Mechanics
Faculty of Mechanical Engineering
Universiti Teknologi Malaysia
81310 Skudai, Johor, Malaysia
Phone: +6-07-5534735, Fax: +6-07-5566159
E-mail: tanghh@fkm.utm.my, musa@fkm.utm.my

ABSTRACT

This paper describes the incorporation of active force control (AFC) scheme into two different resolved motion acceleration control (RMAC) models, i.e. RMAC with proportional-plus-derivative (RMAC-PD) and RMAC with proportional-plus-integral-plus-derivative (RMAC-PID). The two newly formulated control models are subsequently implemented as the proposed motion controllers for the nonholonomic wheeled mobile robot (WMR). By embedding AFC into both the RMAC schemes, the performance of the robotic system was studied in which the WMR was required to track a collision-free trajectory in a structured layout that has been prescribed by a trajectory planner. The effectiveness of both the controllers were then experimented and compared to determine the accuracy and trackability of the WMR. The WMR was also subjected to disturbances for the testing of the system robustness. With appropriately computed inertia matrix and finely tuned RMAC control parameters, the WMR was found to be very robust and effective in trajectory tracking task in spite of the complexity of the operating and loading conditions.

Keywords: *Active force control, motion planning, nonholonomic WMR, resolved motion acceleration control.*

1.0 INTRODUCTION

Rigorous developments in computing technology in the last few decades have brought about drastic improvements and changes in industrial or manufacturing automation sector as can be notably seen in the application of the computer integrated manufacturing (CIM) system and its smaller competitor, the flexible manufacturing system (FMS). As expected, these systems continually demand for more capability and versatility of their key components including the automated material handling equipments. Therefore, these automated transporters or mobile robots with added mobility and maneuverability have been introduced into the manufacturing system to provide greater flexibility and dexterity in materials

handling operations. The limitation of the workspace for the static robotic manipulator has not been able to meet all these requirements. On the other hand, the expansion of the mobile robot's workspace has in fact increased the risk of having the robot to collide with the obstacles or other 'disturbances' along its navigation path. It has been proven that robots were absolutely unsafe and prone to collide among themselves or with the environmental obstacles [1]. Therefore, it is essential that the mobile robotic system should be adequately controlled to ensure that it tracks accurately the predetermined generated trajectory which is normally designed to be safe and cost-effective.

Over the last few decades, considerable efforts have been devoted for the synthesis and analysis of the WMR control strategies, particularly in performing trajectory tracking tasks. Kanayama et al. has achieved local asymptotic tracking of the WMR by using a continuous feedback control law for a linearized kinematic WMR model [2]. As inspired by Kanayama et al., Fierro and Lewis extended the control scheme by using the backstepping control approach [3] in which the control strategy aims to provide a solution to the usual WMR motion control problems, i.e. the path following and point stabilization problems. Samson has provided a global asymptotic control solution for the setpoint regulation of a general class of nonholonomic systems to further enhance the performance of the WMR [4]. Besides, Farzad and Karlsson have also derived an adaptive control scheme for WMR which guarantees the asymptotic convergence of the trajectory tracking errors to zero [5]. These control strategies though effective, they lack the capability to reject disturbances. In other words, they are not sufficiently robust and effective in encountering the external loading conditions exerted upon the dynamic systems. In reality, the workspace for the WMR is not always ideal as it is usually subject to all forms of disturbances such as fixed or moving obstacles, frictions, uncertainties and changes in the operating parameters (internal and external). It is almost impossible to completely model such disturbances into the dynamics of the WMR since the disturbance functions are indiscriminate and often highly nonlinear. Therefore, in order to ensure robust and accurate operation of the WMR, it is proposed that an AFC strategy be incorporated into the robotic system as the robust disturbance cancellation scheme. In the past, AFC has been effectively applied to a number of dynamic systems involving rigid robotic manipulators [6-8], direct drive motors [9] and mechanical system [10]. In all of these works, AFC has shown significant credibility towards improving and achieving the systems robustness upon satisfying the main criterion, i.e. the estimated parameters (mass or inertia) are appropriately computed.

Section 2 of this paper describes the architecture of the proposed WMR control scheme followed by a description of the kinematic and dynamic modelling of the nonholonomic WMR. The design of the WMR motion controller comprising the RMAC and AFC is reviewed in Section 3. Section 4 depicts the simulation setup, results and brief discussion. Finally, Section 5 provides the concluding remarks.

2.0 ARCHITECTURE OF WMR CONTROL SYSTEM

In this paper, the WMR is assumed to be located on a two dimensional plane in which a global Cartesian coordinate system is defined at the reference point, O . The heading direction, $\phi(t)$ is taken as positive in counter-clockwise from x -axis as shown in Figure 1 which shows a configuration of the differentially driven WMR.

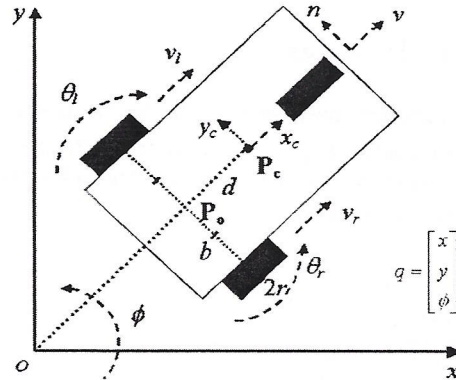

Figure 1. Configuration of a WMR

Two coordinate axes are applied in this study, i.e. the global x - y axis and local v - n axis. Compared to the local v - n axis, the global x - y axis describes the states, q of WMR better in the workspace. However, it is easier to control the WMR in local v - n axis. The following equation is used to transform the states of the WMR from the global x - y axis to local v - n axis:

$$[q_{\text{local}}] = \begin{bmatrix} \cos \phi & \sin \phi & 0 \\ -\sin \phi & \cos \phi & 0 \\ 0 & 0 & 1 \end{bmatrix} [q_{\text{global}}] \quad (1)$$

The proposed WMR control scheme as shown in Figure 2, generally consists of two stages: high-level control and low-level control. High-level control which is commonly known as motion planning helps to break down the high-level control tasks into the low-level motion execution commands. It is usually comprised of two components, i.e. path planning and trajectory planning. At higher-level, motion planning is required to generate a collision-free nonholonomic trajectory with reference to the operation time optimality and workspace layout [11]. However, at low-level control, the motion controller is required to implement the pre-planned trajectories or motion commands as have been generated in motion planning phase. A precise and robust motion controller should be designed in such a way that it is able to follow or track exactly the pre-planned trajectory

despite of the complexity of the trajectory plus the presence of disturbances in the workspace. In this study, it is proposed that the basic WMR motion controller is assisted by the AFC method to enhance the robustness of the system.

Basically, the motion of the WMR is restrained by nonholonomic constraints. This is to ensure that the WMR satisfies the conditions of pure rolling and non-slipping while traversing. Details of the kinematic and dynamic modelling of nonholonomic WMR have been extensively reviewed in [12,13]. The general formulation of the WMR dynamic model is shown as follows:

$$\mathbf{M}(q)\ddot{q} + \mathbf{V}(q, \dot{q}) = \mathbf{E}(q)\tau - \mathbf{A}^T(q)\lambda \quad (2)$$

where $\mathbf{M}(q)$ is a symmetric, positive definite inertia matrix, $\mathbf{V}(q, \dot{q})$ is the centripetal and Coriolis matrix, $\mathbf{E}(q)$ is the input transformation matrix, τ is the input torque vector, $\mathbf{A}(q)$ is the matrix associated with the nonholonomic constraints, and λ is the constraint force vector.

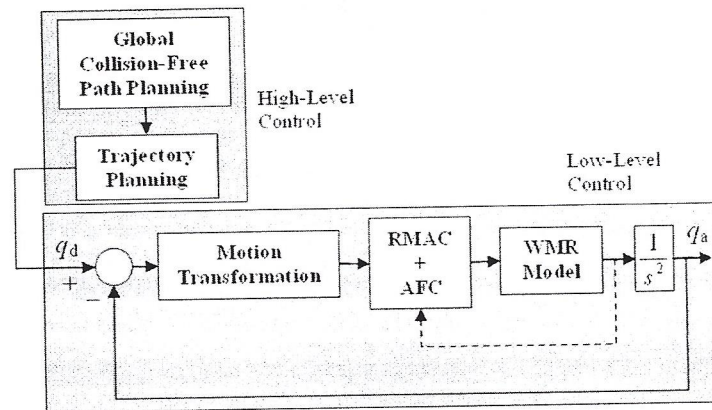

Figure 2. Architecture of the WMR control system

3.0 MOTION CONTROLLER DESIGN

Motion control study deals with the development of the controller which ensures the stabilization of WMR to an equilibrium point or to a reference trajectory. The most crucial problem in the stabilization of WMR centres around the fact that the WMR does not meet Brockett's necessary smooth feedback stabilization condition where the system cannot be stabilized by continuous feedback which is dependent on the states of the system [14]. Due to these nonholonomic constraints, the number of controllable degree-of-freedom (DOF) of the WMR has been reduced to two while the total DOF of WMR is three.

As has been pointed out in [15], the larger the gap between the controllable and total DOF of WMR, the harder it is to control the robot. Since it is difficult to stabilize the WMR to a point with smooth static-state feedback control laws, instead of stabilizing the WMR to a point, the robot is required to converge to a reference trajectory only in this study [16]. Figure 3 illustrates the block diagram of the proposed motion control scheme.

3.1 Resolved Motion Acceleration Control (RMAC)

In resolved motion control, the motions of various motors are combined and resolved into separately controllable motions along the world coordinate axes. This implies that all the motors of the robot must run simultaneously at different time-varying rates to achieve desired coordinated motions [17]. Through this control scheme, the users need only to specify the desired direction and speed along the world coordinate axes and this greatly facilitate the interaction between users and the WMR. Usually, users are more adapted to Cartesian coordinate system compared to the motor rotation angle coordinates. RMAC was first proposed by Luh et al. [18] for the motion control of static manipulator. It is actually an extension of the concept of resolved motion rate control by just adding in the extra acceleration control command. Generally, all the feedback control are accomplished at a pre-specified point, P_c on the WMR (which is at the centre of gravity of WMR).

In this study, two types of RMAC scheme have been studied, i.e. RMAC-PD and RMAC-PID. Assuming that K_p , K_d and K_i (being the proportional, derivative and integral control gains respectively) are positive definite gains, the acceleration commands by the RMAC-PD scheme can thus be expressed as follows:

$$\begin{aligned}\ddot{x}_c &= \ddot{x}_d + K_{dx}(\dot{x}_d - \dot{x}_a) + K_{px}(x_d - x_a) \\ \ddot{y}_c &= \ddot{y}_d + K_{dy}(\dot{y}_d - \dot{y}_a) + K_{py}(y_d - y_a) \\ \ddot{\phi}_c &= \ddot{\phi}_d + K_{d\phi}(\dot{\phi}_d - \dot{\phi}_a) + K_{p\phi} \sin(\phi_d - \phi_a)\end{aligned}\tag{3}$$

The acceleration commands generated by the RMAC-PID scheme are given by:

$$\begin{aligned}\ddot{x}_c &= \ddot{x}_d + K_{dx}(\dot{x}_d - \dot{x}_a) + \left(K_{px} + \frac{K_{ix}}{s}\right)(x_d - x_a) \\ \ddot{y}_c &= \ddot{y}_d + K_{dy}(\dot{y}_d - \dot{y}_a) + \left(K_{py} + \frac{K_{iy}}{s}\right)(y_d - y_a) \\ \ddot{\phi}_c &= \ddot{\phi}_d + K_{d\phi}(\dot{\phi}_d - \dot{\phi}_a) + \left(K_{p\phi} + \frac{K_{i\phi}}{s}\right) \sin(\phi_d - \phi_a)\end{aligned}\tag{4}$$

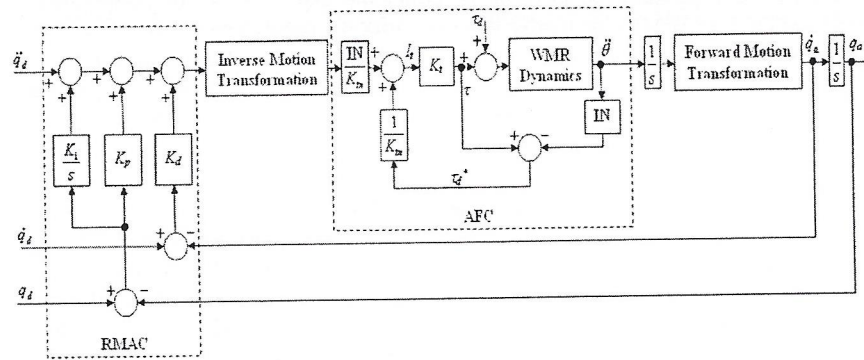

Figure 3. Block diagram of the proposed WMR motion controller

One of the major concerns in applying RMAC into the WMR motion controller is that the total DOF of WMR is three while controllable DOF is only two. Therefore, the DOF for the control signals generated by RMAC, which are initially three, have to be stepped down to two. In order to achieve this, the acceleration control signals by RMAC are first transformed from global x - y axis into local v - n axis using Equation (1). With reference to the stable tracking controller as proposed by Kanayama et al. [2], a converter can be modelled as follows:

$$\begin{bmatrix} \dot{v} \\ \dot{\omega} \end{bmatrix} = \begin{bmatrix} \ddot{x}_{\text{local}} \\ \dot{y}_{\text{local}} \xi + \ddot{\phi}_{\text{local}} \end{bmatrix} \quad (5)$$

Due to the nonholonomic constraints, motion along local n -axis is in fact uncontrollable. Therefore, the corrective acceleration signal, \dot{y}_{local} should be multiplied to ξ , i.e. the virtual radius to obtain an additional corrective rotational acceleration signal. This additional corrective rotational acceleration signal is required to steer the WMR towards the pre-planned states and thus ensures the convergence of the trajectory tracking errors.

3.2 Active Force Control (AFC)

The incorporation of AFC into the motion control scheme of WMR provides a dynamic decoupled control feature that is complemented with a convenient coordinate system. System controlled by AFC remains stable, robust and effective although the system is subjected to adverse operating and loading conditions [6]. In addition, AFC also ensures that the motion controller is highly tolerant and accommodating even to inaccurate modelling of the system and its workspace. The essential equation describing the estimated disturbances, τ_d^* in the AFC loop (for a rotating system) is expressed by [6]:

$$\tau_d^* = \tau - \mathbf{IN}\ddot{\theta} \quad (6)$$

where $\ddot{\theta}$ is the motor angular acceleration signal, \mathbf{IN} is the estimated inertia matrix and τ is the applied control torque. Note that Equation (6) could have practical implication due to the fact that the algorithm is very simple (thus much less computational burden) and easily implemented in real-time. Both the acceleration signal and control torque could be physically measured by means of suitable transducers, i.e. accelerometer and torque sensor respectively. Alternatively, a current sensor can be used in place of the torque sensor to indirectly measure the torque according to the following relationship:

$$\tau = K_t I_t \quad (7)$$

where I_t is the motor current and K_t the motor torque constant.

In this study, a perfect modelling was assumed for the measurements while a crude approximation method was used for the estimation of \mathbf{IN} . It has been ascertained that the estimation of \mathbf{IN} is a requisite to the AFC scheme. From a number of trial runs, it has been shown that the AFC scheme works effectively if the chosen \mathbf{IN} lies within a finite bound of the modelled inertia matrix, $\bar{\mathbf{M}}$ such that [19]:

$$0.4\bar{\mathbf{M}} < \mathbf{IN} < 1.2\bar{\mathbf{M}} \quad (8)$$

Assuming that $\mathbf{A}(q)$ is the set of nonholonomic constraints of the WMR, and there exists $\mathbf{S}(q)$ such that $\mathbf{S}(q)\mathbf{A}(q) = 0$, $\bar{\mathbf{M}}$ can thus be obtained from (1) as follows:

$$\begin{aligned} \left[\mathbf{S}^T \mathbf{M} \mathbf{S} \right] \ddot{\theta} + \left[\mathbf{S}^T \mathbf{V} + \mathbf{S}^T \mathbf{M} \dot{\mathbf{S}} \dot{\theta} \right] &= \mathbf{S}^T \mathbf{E} \tau \\ \bar{\mathbf{M}}(q) \ddot{\theta} + \bar{\mathbf{V}}(q, \dot{q}) &= \bar{\mathbf{E}}(q) \tau \end{aligned} \quad (9)$$

where $\dot{\theta}_r$ and $\dot{\theta}_l$ are the angular velocities of right and left motor respectively. Let α be the ratio of \mathbf{IN} with respect to $\bar{\mathbf{M}}$ and follows strictly the bound defined in (8). Assuming that the off-diagonal terms of $\bar{\mathbf{M}}$ are relatively small and can be safely neglected, \mathbf{IN} can thus be estimated as follows:

$$\begin{bmatrix} \mathbf{IN}_{11} & 0 \\ 0 & \mathbf{IN}_{22} \end{bmatrix} = \alpha \begin{bmatrix} \bar{\mathbf{M}}_{11} & 0 \\ 0 & \bar{\mathbf{M}}_{22} \end{bmatrix} \quad (10)$$

4.0 SIMULATION

The simulation was performed using the computation platform provided by MATLAB and Simulink. During the simulation, the performance for both RMAC-PD and RMAC-PID control schemes was tested under the same operating conditions and workspace. It was assumed that the workspace for the WMR was known and the tracking trajectory predefined by a motion planner. Besides, the WMR was also subjected to a number of disturbances to test the robustness of the proposed motion control systems. The parameters and conditions that have been acquired after a number of trial runs prior to the simulation study are listed as follows:

WMR Parameters:

$$r = 0.15 \text{ m}, b = 0.75 \text{ m}, d = 0.1 \text{ m}, m_{\text{chassis}} = 30.0 \text{ kg}, \xi = 1$$

Parameters of RMAC-PD:

$$K_{px} = 70, K_{py} = 70, K_{p\phi} = 70$$

$$K_{dx} = 15, K_{dy} = 15, K_{d\phi} = 15$$

Parameters of RMAC-PID:

$$K_{px} = 70, K_{py} = 70, K_{p\phi} = 70$$

$$K_{dx} = 15, K_{dy} = 15, K_{d\phi} = 15$$

$$K_{ix} = 25, K_{iy} = 25, K_{i\phi} = 25$$

Parameters of AFC:

$$\alpha = \frac{\mathbf{IN}}{\mathbf{M}} = 1, \beta = \frac{K_t}{K_m} = 1$$

(Note: It is assumed that \mathbf{IN} and K_m were perfectly modelled)

Disturbance Models:

$$\text{Step disturbance, } \tau_a = \begin{cases} t < 35\text{sec} & [0; 0] \text{Nm} \\ t \geq 35\text{sec} & [5; 5] \text{Nm} \end{cases}$$

$$\text{Harmonic disturbance, } \tau_h = \begin{bmatrix} 3 \sin(0.4t) + 3 \\ 3 \sin(0.4t + \pi) + 3 \end{bmatrix} \text{ Nm}$$

Figure 4 illustrates the pre-planned trajectory by the motion planner. From the figure, it can be observed that the motion planner has successfully generated a near optimum and short collision-free trajectory. The generated trajectory has actually fulfilled the nonholonomic constraints of the WMR.

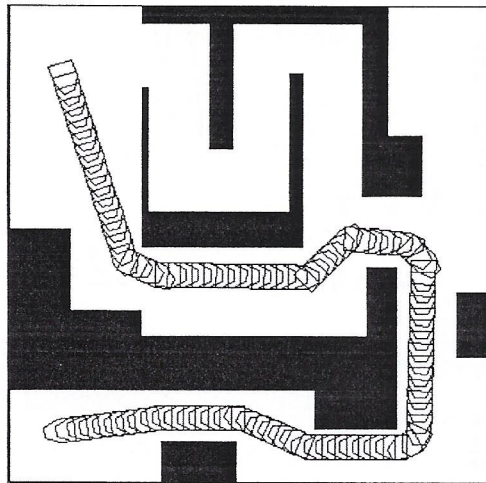

Figure 4. Pre-planned trajectory by motion planner

Figures 5 to 7 illustrate the trajectory tracking errors of the WMR. From the simulation results, it is observed that the state errors either of the RMAC-PD controller or the RMAC-PID controller experiences drastic changes whenever the WMR is required to turn or change its heading direction. This type of WMR behaviour can actually be deduced intuitively by observing the error trend in Figure 7. It can be seen that the WMR orientation errors abruptly produce 'spikes' whenever the WMR is expected to turn. This indicates that the pre-planned trajectory is crisp and smoother planning of trajectory is required.

From the simulation, the RMAC-PID controller is found to outperform the RMAC-PD counterpart. By adding the integral term, the output states of the WMR is able to converge gradually to the prescribed trajectory and thus achieve better trajectory tracking capability as well as maneuverability. RMAC-PID controller is also capable of *y*-axis motion errors compensation in spite of the nonholonomic constraints. However, if the WMR is controlled by RMAC-PD (without the *I* term), the steady state errors remain uncompensated during the

operation. On the other hand, it is also noted that the integral action will cause overshooting to the response as shown in Figure 5. To counter this, it is envisaged that the K_i parameters should be carefully tuned.

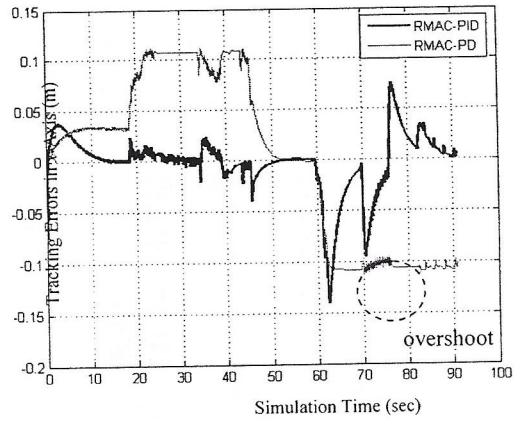

Figure 5. Tracking errors in x -axis

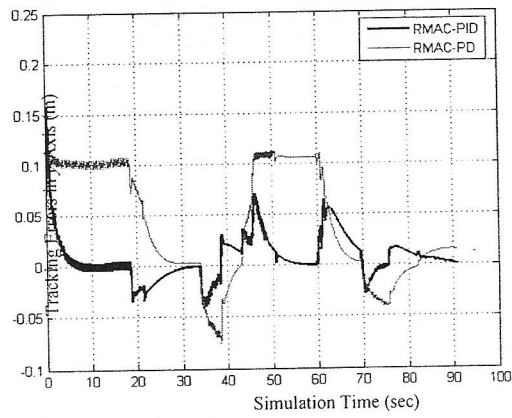

Figure 6. Tracking errors in y -axis

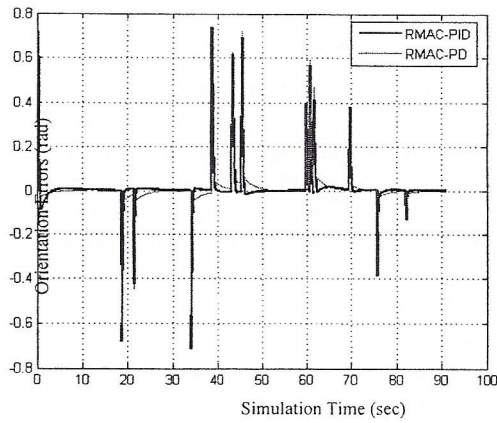

Figure 7. Orientation errors

With reference to Table 1, it is obvious that the motion controller which consists of RMAC and AFC is capable of performing disturbance cancellation task. The incorporation of AFC has significantly improved the robustness of the WMR system although it is operated in a non-ideal environment, where the existence of disturbances is unavoidable. With properly estimated \mathbf{IN} , AFC displays superiority in the suppression of the state errors which are caused by the internal and external disturbances. With AFC, both of the RMAC-PID and RMAC-PD controllers are robust in nature. However, it is RMAC that plays a vital role in the improvement of the overall system's performance and trajectory trackability. It has been shown from the simulation results that the percentage of deviation of state errors for the RMAC-PID controller are very low, i.e. less than 5% compared to those of the RMAC-PD controller which are relatively higher. Although the percentage of deviation for RMAC-PD can be further improved by increasing the value of K_p and K_d , it is expected that the response might suffer deterioration of the system stability and subject to limit cycles.

Table 1: Percentage deviation of state errors

Types of Controller	Percentage of Deviation (%)		
	x_e	y_e	ϕ_e
RMAC-PD	6.89	5.64	4.27
RMAC-PID	1.64	1.74	3.40

5.0 CONCLUSIONS

The implementation of AFC into both RMAC-PD and RMAC-PID schemes has been shown to provide excellent all round performance. The RMAC-PID scheme is found to outperform the RMAC-PD counterpart since the percentage of deviation of the state errors of RMAC-PID are much lesser than its competitor. By adding the integral action into RMAC, the output states of the WMR is able to converge gradually to the prescribed trajectory and achieve better trajectory tracking capability even in the presence of the nonholonomic constraints of the WMR and introduced disturbances. However, integral action also causes overshooting in the WMR system response. In this study, the values of α and β are set to 1 indicating that \mathbf{IN} and K_m are perfectly modelled. With these ideally estimated AFC parameters, AFC has shown superiority in disturbance compensation and thus significantly improved the robustness of the robotic system. In future, it is recommended that the stability of the WMR motion control system should be further tested through more rigorous study. Besides, the RMAC control gains should also be properly tuned so that the performance of the system can be further enhanced.

ACKNOWLEDGEMENT

The authors would like to acknowledge the Research Management Centre (RMC), Universiti Teknologi Malaysia for providing the financial support for the research through Vote No. 75273.

REFERENCES

1. Cameron, S. (1994), "Tutorial: Obstacle Avoidance and Path Planning," *Industrial Robot*, vol. 21, no. 4, pp. 9-14.
2. Kanayama, Y., Kimura, Y., Miyazaki, F., Noguchi, T. (1990), "A Stable Tracking Control Method for An Autonomous Mobile Robot," *Proc. Of 1990 IEEE International Conference on Robotics and Automation*, vol. 1, pp. 384-389.
3. Fierro, R., Lewis, F. L. (1995), "Control of a Nonholonomic Mobile Robot: Backstepping Kinematics into Dynamics," *Procs. of 34th IEEE Conference on Decision and Control*, pp. 3805-3810.
4. Samson, C. (1995), "Control of Chained Systems Application to Path Following and Time-Varying Point Stabilization of Mobile Robots," *IEEE Transactions on Automatic Control*, vol. 40, no. 1, pp. 64-77.
5. Farzad, P., Karlsson, M.P. (2000), "Adaptive Control of Dynamic Mobile Robots with Nonholonomic Constraints," *Computers and Electrical Engineering*, vol. 28, pp. 241-253.

6. Hewit, J. R., Burdess, J. R. (1981), "Fast Dynamic Decoupled Control for Robotic Arm Using Active Force Control," *Mechanism and Machine Theory*, vol. 16, no. 5, pp. 535-542.
7. Murakami, T., Oda, N., Miyasaka, Y., Ohnishi, K. (1995), "A Motion Control Strategy Based on Equivalent Mass Matrix in Multidegree-of-Freedom Manipulator," *IEEE Transactions on Industrial Electronics*, vol. 42, no. 2, pp. 123-130.
8. Pitowarno, E., Mailah M., Jamaluddin, H. (2002), "Knowledge-Based Trajectory Error Pattern Method Applied to An Active Force Control Scheme", *International Journal of Engineering and Technology*, UIAM, vol. 2, no.1, pp. 1-15.
9. Komada, S., Ishida, M., Ohnishi, K., Hori, T. (1991), "Disturbance Observer-Based Motion Control of Direct Drive Motors," *IEEE Transactions on Energy Conversion*, vol. 6, no. 3, pp. 553-559.
10. Burdess, J. S., Hewit, J. R. (1986), "An Active Method for the Control of Mechanical Systems in the Presence of Unmeasurable Forcing," *Mechanism and Machine Theory*, vol. 21, no. 3, pp. 393-400.
11. Fraichard, T., Langier, C., Liévin, G. (1990), "Robot Motion Planning: The Case of Non Holonomic Mobiles in A Dynamic World," *Proc. Of 1990 IEEE International Workshop on Intelligent Robots and Systems – Towards a New Frontier of Application*, pp. 757-764.
12. Yamamoto, Y., Yun, X. (1994), "Coordinating Locomotion and Manipulation of A Mobile Manipulator," *IEEE Transactions on Robotics and Automation*, vol. 39, no. 6, pp. 1326-1332.
13. Murray, R. M., Li, Z., Sastry, S.S.A.(1994), *Mathematical Introduction to Robotic Manipulation*, United States of America: CRC Press, Inc.
14. Brockett, R.W. (1983), "Asymptotic Stability and Feedback Stabilization," in *Differential Geometric Control Theory*", R.W. Brockett, and R.S. Milman, Eds. H.J. Sussman: Birkhäuser Boston, Inc., pp. 181-191.
15. Laumond, J.P., Simeon, T., Chatila, R., Giralt, G. (1989), "Trajectory Planning and Motion Control of Mobile Robots," in *Dynamics of Controlled Mechanical Systems IUTAM/IFAC Symposium Zurich/Switzerland 1988*, G. Schweitzerand, Eds. M. Mansour: Springer-Verlag Berlin Heidelberg, pp. 351-366.
16. Walsh, G., Tilbury, D., Sastry, S., Murray, R., Laumond, J.P. (1994), "Stabilization of Trajectories for Systems with Nonholonomic Constraints," *IEEE Transactions on Automatic Control*, vol. 39, no. 1, pp. 216-222.
17. Fu, K.S., Gonzalez, R.C., Lee, C.S.G. (1987), *Robotics: Control, Sensing, Vision, and Intelligence*, Singapore: McGraw-Hill Book Company.
18. Luh, M. W. Walker, Paul, R.P.C. (1980), "Resolved-Acceleration Control of Mechanical Manipulators," *IEEE Transactions on Automatic Control*, vol. 25, no. 3, pp. 468-474.
19. Mailah, M., Hewit, J.R., Meeran, S. (1996), "Active Force Control Applied to A Rigid Robot Arm," *Jurnal Mekanikal*, vol. 2, pp. 52-68.

