

## **DEVELOPMENT OF SOLID ROCKET PROPULSION SYSTEM AT UTM**

Mohammad Nazri Mohd. Jaafar  
Wan Khairuddin Wan Ali  
Md Nizam Dahalan

Department of Aeronautic & Automotive  
Faculty of Mechanical engineering  
Universiti Teknologi Malaysia  
81310 Skudai, Johor

Rizalman Mamat  
Faculty of Mechanical Engineering  
University College of Engineering and Technology Malaysia  
MBC Campus  
Kuantan, Pahang

### **ABSTRACT**

*Rockets have been used from as early as the thirteenth century as fireworks and weapons. However, since then the usage of rockets have been diversified. Nowadays, rockets are used from as small as model rocketry for hobbyist to as large as a satellite launcher. Another diversified usages of rockets is as a launch vehicle for cloud seeding.*

*In line with this, over the past decade Universiti Teknologi Malaysia (UTM) has been developing capabilities to launch a small rocket. Due to the low cost of raw materials and ease of production process, composite propellant is the best choice for this purpose. Potassium nitrate based solid propellant has been investigated in order to study their properties and performance. As a result, it is found that this propellant is capable of reaching the necessary range for cloud seeding (6 km - 7 km).*

**Keywords:** *Solid rocket, potassium nitrate, solid rocket motor, static thrust.*

### **1.0 INTRODUCTION**

A rocket is a device that develops thrust by rapid expulsion of matter. The major components of a chemical rocket assembly are a rocket motor or engine, propellant consisting of fuel and oxidizer, a frame to hold the components, control systems and payload such as a satellite. A rocket differs from other engines in that it carries its fuel and oxidizer internally, therefore it can burn in the vacuum of space as well as within the Earth's atmosphere [1]. A rocket is called a launch vehicle when it is used to launch a satellite or other payload into space. A rocket becomes a missile when the payload is a warhead and it is used as a weapon. At present, rockets are the only means capable of achieving the

altitude and velocity necessary to put a payload into orbit. Now rocket is also used for weather modification such as hail suppression and cloud seeding for rain. The technology was successfully applied for cloud seeding by some countries such as Russia and China.

Many different types of rocket engines have been designed or proposed. Currently, the most powerful are the chemical rocket engines. Other types of rocket being designed or that are proposed are ion rockets, photon rockets, magneto hydrodynamic drives and nuclear fission rockets; however, they are generally more suitable for providing long term thrust in space rather than launching a rocket and its payload from the Earth's surface into space.

There are three categories of chemical rocket engines: liquid propellant, solid propellant, and hybrid propellant. The propellant for a chemical rocket engine usually consists of a fuel and an oxidizer. Sometimes a catalyst is added to enhance the chemical reaction between the fuel and the oxidizer. Each category has advantages and disadvantages that make them best for certain applications and unsuitable for others.

Solid propellant rockets are basically combustion chamber tubes. The tubes are packed with a propellant that contains both fuel and oxidizer. The principal advantage is that a solid propellant is relatively stable therefore it can be manufactured and stored for future use. Solid propellants have a high density and can burn very fast. They are relatively insensitive to shock, vibration and acceleration. No propellant pumps are required thus the rocket engines are less complicated. Disadvantages are that, once ignited, solid propellants cannot be throttled, turned off and then restarted because they burn until all the propellant is used. The surface area of the burning propellant is critical in determining the amount of thrust being generated. Cracks in the solid propellant increase the exposed surface area, thus the propellant burns faster than planned. If too many cracks develop, pressure inside the engine rises significantly and the rocket engine may explode [2].

## **2.0 DEVELOPMENT OF SOLID ROCKET PROPULSION SYSTEM**

The development of solid rocket propulsion system at UTM can be divided into three stages. The first stage is the development of the solid propellant itself. At UTM, potassium nitrate was used due to the ease of availability and fabrication. The second stage involves the development of solid propellant performance tests rig. These include the burning test rig and the static thrust test rig. The development of the solid rocket motor (SRM) for static thrust test rig was also done at UTM. Finally, the flight tests were performed to observe the feasibility of this propellant to propel the launch vehicle for cloud seeding.

## 2.1 Properties of Solid Propellant

An investigation of potassium nitrate and sucrose (KS) as solid rocket propellant has been carried out at UTM. The propellant was produced using press-molding method and tested in a rocket motor to obtain its performance characteristics. The rocket motor was used to investigate the pressure exponent and index of the propellant. From the experiment, it was found that the pressure index and pressure exponent of the propellant are 0.3 and  $1.5 \times 10^{-4} \text{ m}^2\text{s/kg}$  respectively.

At room temperature the color of KS propellant is golden honey. The KS propellant is brittle in nature. In its casted form, the propellant is hygroscopic and water-soluble. One of the combustion products is potassium carbonate, which is hygroscopic and absorbs moisture from air to form an aqueous solution of hydroxide ions, which can be rather corrosive. Potassium nitrate is toxic in its natural state, which can cause methemoglobinemia when swallowed [3]. Symptoms of nausea, vomiting and acidosis are also likely. This propellant should be handled with care. Potassium nitrate is a powerful oxidizer, dangerous, and fire and explosion hazard [4]. It should be stored in a cool, dry and isolated place. Figure 5 shows how KS propellant surface looks like under the SEM scanning [5]. It clearly shows the color difference between potassium nitrate and sucrose particles. Under the curing process, sucrose melts whereas potassium nitrate is still in solid form as long as its melting temperature has not been reached [6].

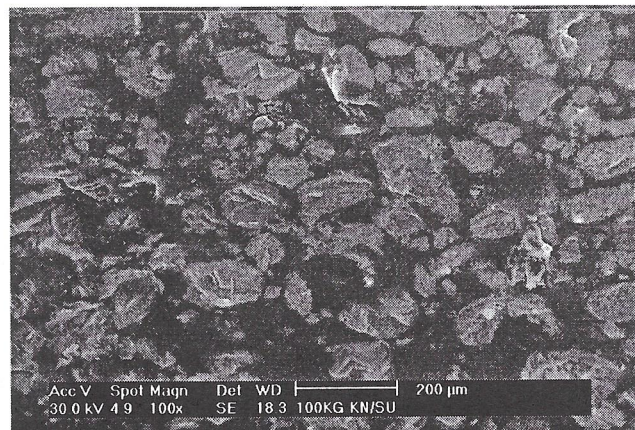

Figure 1 Propellant grain

During the initial investigation, a lab-scale solid rocket motor was designed, constructed and tested to obtain a large database of local burning time and combustion temperature at several critical points over a range of operating conditions. Later a series of static thrust tests were conducted using the solid propellant produced as illustrated in Figure 2.

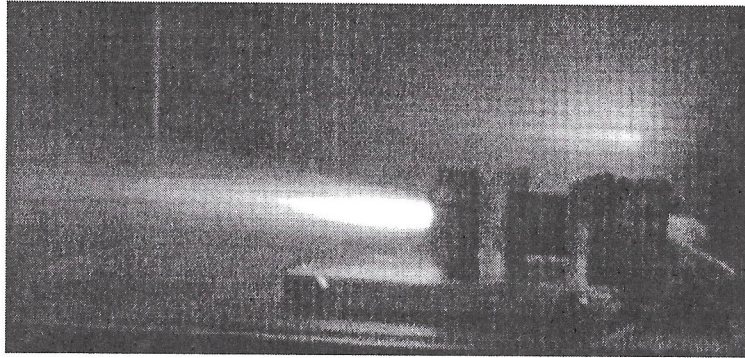

Figure 2 Static thrust test

The thrust produced during the rocket motor operations was measured by self-made load cell with complete accessories such as amplifier and filter. All the data captured was stored in a digital oscilloscope. Based on experimental works, it is found that the potassium nitrate-sucrose propellant produced has the characteristics as shown in Table 1.

Table 1 Comparison between theoretical and experimental values

Parameter	Theoretical	Experimental
Effective molar weight, $M$	42.496 g/mol	-
Specific heat ratio, $k$	1.07	-
Exhaust gas constant, $R$	195.642 J/kg-K	-
Characteristic velocity, $C^*$	942.066 m/s	-
Mass flow factor, $C_m$	$1.06 \times 10^{-3}$ s/m	-
Specific impulse, $I_{sp}$	162.21 s	154.8 s
Effective exhaust velocity, $C$	1,591.3 m/s	1,518.7 m/s
Thrust coefficient, $C_F$	1.69	1.61
Burning rate at $P_c$ , $r_o$	-	0.726 cm/s
Pressure coefficient, $a$	-	$1.5 \times 10^{-4}$ m <sup>2</sup> /s/kg
Pressure index, $n$	-	0.3

## 2.2 Solid Rocket Motor

The mechanical components of a rocket motor are mainly comprised of a combustion chamber and exhaust nozzle. The combustion chamber is essentially a pressure vessel containing the propellant. This chamber must be strong enough to sustain high pressure and temperature of the combustion products. Consider a closed cylinder of pressure vessel subjected to an internal pressure,  $P$  as shown in Figure 3.

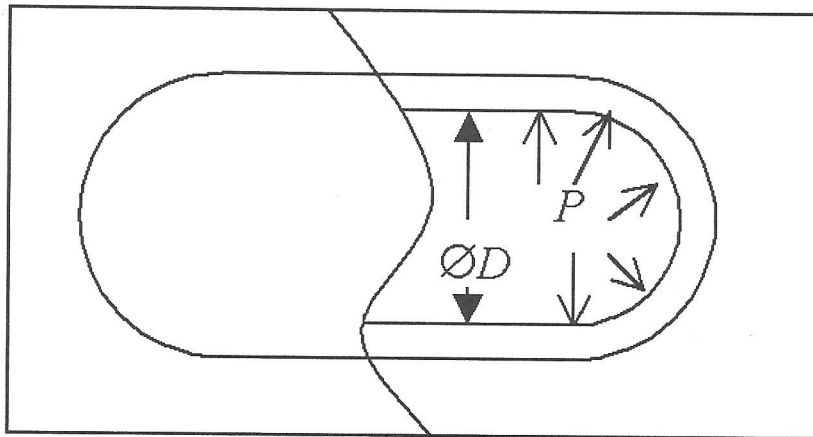

Figure 3 Closed cylindrical vessels

Figure 4 shows a free-body diagram of a portion of the cylinder cross-section. The external pressure force acts on the closed end and an internal axial tensile force acts within the wall. The conventional analysis of stresses and strains in a solid propellant rocket motor are based on the assumptions that the strains are small and a state of plane strain exist in the grain [7]. The tensile force in terms of the average longitudinal stress,  $\sigma_1$  across the severed circumferential area,  $A$  is as follows:

Thus,

$$\sigma_1 A = \sigma_1 \pi D_t \quad (1)$$

To maintain equilibrium in the longitudinal direction, the tensile force and the pressure force must be equal. Thus,

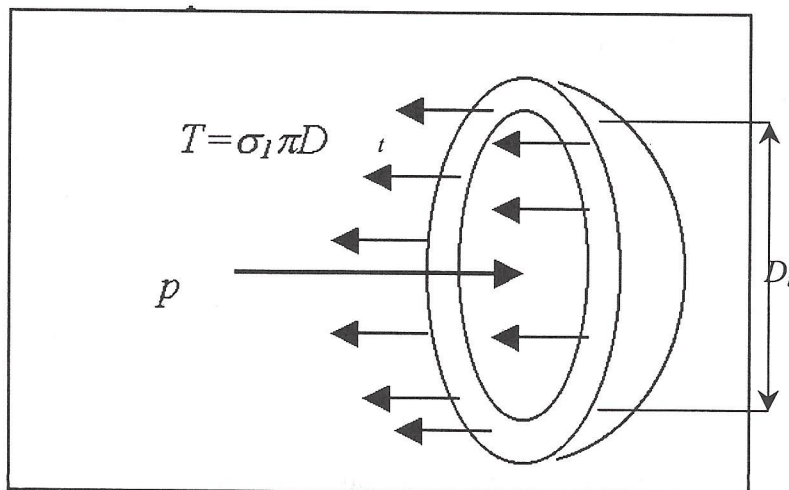

Figure 4 Free-body diagram of a portion of the cylinder cross-section

$$\sigma_1 \pi D_i = p \frac{1}{4} \pi D^2 \quad (2)$$

$$\sigma_1 = \frac{pD}{4t}$$

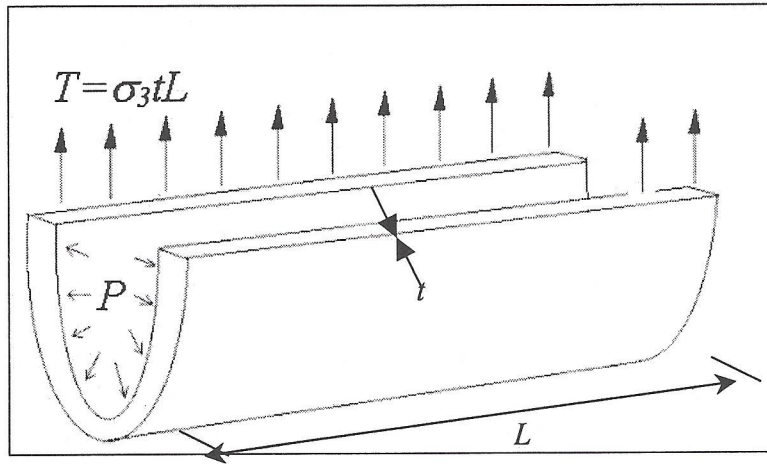

Figure 5 Circumferential stress on the cylinder wall

Circumferential stress,  $\sigma_3$  acts at the wall of the cylinder as shown in Figure 5. This case includes the portion of the pressurized gas or liquid contained by this segment of the cylinder. The forces in the vertical direction include a pressure force equal to the product of the internal pressure,  $P$  and the area  $LD$ , and tensile forces on each of the two severed areas. The tensile forces in terms of the circumferential stress on the severed area  $A$  is,

$$\sigma_3 A = \sigma_3 Lt \quad (3)$$

To maintain equilibrium, then

$$\sigma_3 Lt = \frac{1}{2} pLD \quad (4)$$

$$\sigma_3 = \frac{pD}{2t}$$

An average radial stress,  $\sigma_2$  is given as follow

$$\sigma_2 = -\frac{1}{2} p \quad (5)$$

While the yield criteria is given by the equation below

$$(\sigma_1 - \sigma_2)^2 + (\sigma_2 - \sigma_3)^2 + (\sigma_3 - \sigma_1)^2 = 2\sigma_v^2 \quad (6)$$

where  $\sigma_v$  is the tensile yield stress of the vessel material. To avoid any lasting plastic deformation, the design of SRM should consider a safety factor,  $S_f$

$$S_f = \frac{\sigma_v}{\sigma_{ref}} \quad (7)$$

where  $\sigma_{ref}$  is a reference tensile stress in terms of, when  $\sigma_{ref} = \sigma_v$  yield conditions is reached, when  $\sigma_{ref} < \sigma_v$  purely plastic deformation occurred. Quality tube for hot steam application uses a safety factor of approximately 1.5 as international standard.

The connection correlation of the safety factor is then specified as

$$S_{fz} = zS_f = \frac{z\sigma_v}{\sigma_{ref}} \quad (8)$$

Equation (6), the von Mises-criteria, then takes the form of

$$(\sigma_1 - \sigma_2)^2 + (\sigma_2 - \sigma_3)^2 + (\sigma_3 - \sigma_1)^2 = 2 \left( \frac{z\sigma_v}{S_f} \right)^2 \quad (9)$$

Whereas either the maximum pressure for a given vessel or the minimum wall thickness  $t$  for a given pressure and diameter is sought in the analysis, solving Equation (9), by using equation (2), (4) and (5), gives

$$\text{Maximum pressure, } P_{\max} = \frac{4t}{\sqrt{3D^2 + 6Dt + 4t^2}} \left( \frac{z\sigma_v}{S_f} \right) \quad (10)$$

$$\text{Minimum thickness, } t_{\min} = \left( \frac{3 + \sqrt{48Q^2 - 3}}{16Q^2 - 4} \right) D \quad (11)$$

$$Q = \frac{z\sigma_v}{pS_f} \quad (12)$$

### **2.2.1 Nozzle Design**

There are several types of nozzle usually used for SRM. Fixed, external, submerged, blast tube, and thrust vector control is the commonly used nozzle in tactical missiles and other rocket applications. Most rocket motors use convergent-divergent nozzle. The convergent and divergent sections may be conical, but other geometries, such as contoured or bell-shaped nozzles, are used.

The nozzle is an important element of the turbojet, ramjet and rocket engines, since it is the thrust-producing element of these propulsion engines. An increase

in specific impulse obtained with an increase in combustion chamber pressure is almost entirely caused by the increase in expansion ratio through the nozzle [8]. The specific impulse is defined as the engine thrust divided by the mass flow rate of the propellants and tell us how effectively the thrust chamber converts propellant into thrust [9]. The analytical treatment of the flow through the nozzles is based on assuming, as first approximation, that the flow is isentropic [10]. The nozzle throat diameter inversely affects motor operating pressure as noted by the simplified steady-state mass balance equation involving the propellant physical grain geometry and burning characteristics as follows;

$$P_c = \left[ \frac{\rho_p C^* A_b r_b}{A_t P^n} \right]^{\frac{1}{1-n}} \quad (13)$$

- where,
- $P$  = chamber pressure
  - $\rho_p$  = propellant density
  - $A_b$  = propellant burning surface area
  - $r_b$  = propellant burn rate
  - $A_t$  = nozzle throat area
  - $n$  = propellant burn rate exponent
  - $g$  = gravity acceleration
  - $C^*$  = characteristic velocity

Operating temperatures, pressures, and gas velocities vary widely from region to region. Gas flow velocities range from nearly stagnant Mach number of less than 0.1 to Mach number 1.0 at the throat to supersonic Mach number greater than 5 at the exit plane. The nozzle designed for this project is shown in Figure 6.

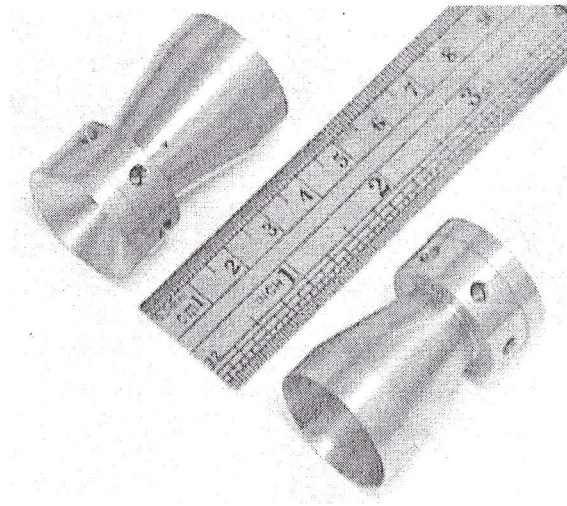

Figure 6 Convergent-divergent nozzle for rocket motor



### 3.0 FLIGHT TEST

Several types of rocket models were launched at UTM and one of them is LAYANG-1 model. The objective is to achieve a typical altitude of around 1.7 to 2.8 km. The model has 1-liter payload volumes. During the early flight tests, no payload was loaded onto the model. The rocket was launched from sea level to a target altitude and was not recovered.

LAYANG-1 consists of three main components: nose, body and fins. The nose cone was fabricated from balsa wood in order to attain lightweight. The ogive type nose was selected due to its aerodynamic shape. The technical data for LAYANG-1 model are given in Table 2.

Table 2 Technical data for rocket model (LAYANG –1)

Nose	Type	Ogive
	Material	Wood
	Weight	93 g
	Length	110 mm
	Diameter	43 mm
Body	Type	Cylinder
	Material	Plastic
	Weight	291 g
	Diameter	43 mm
	Length	990 mm
Fin	Type	Swept back
	Fin count	3
	Material	Plastic
	Weight each	26 g
	Total Weight	78 g
Total	Length	1,100 mm (1.1 m)
	Weight (without AR-1 RM)	462 g
	Weight (with AR-1 RM)	807 g
	AR- 1 RM Weight	345 g

LAYANG-1 rocket uses AR-1 rocket motor and flew up to 1 km. AR-1 rocket motor has an outer diameter of 28 mm and total length of 200 mm. Weighing about 345 g, the engine can produce a maximum thrust of up to 300 N. At ambient temperature and pressure, the rocket motor produces average thrust and total impulse of 188 N and 150 Ns, respectively. Figure 7 shows a typical thrust profile for AR-1 rocket motor. Meanwhile, Figure 8 shows the LAYANG-1 rocket loaded with AR-1 rocket motor in flight.

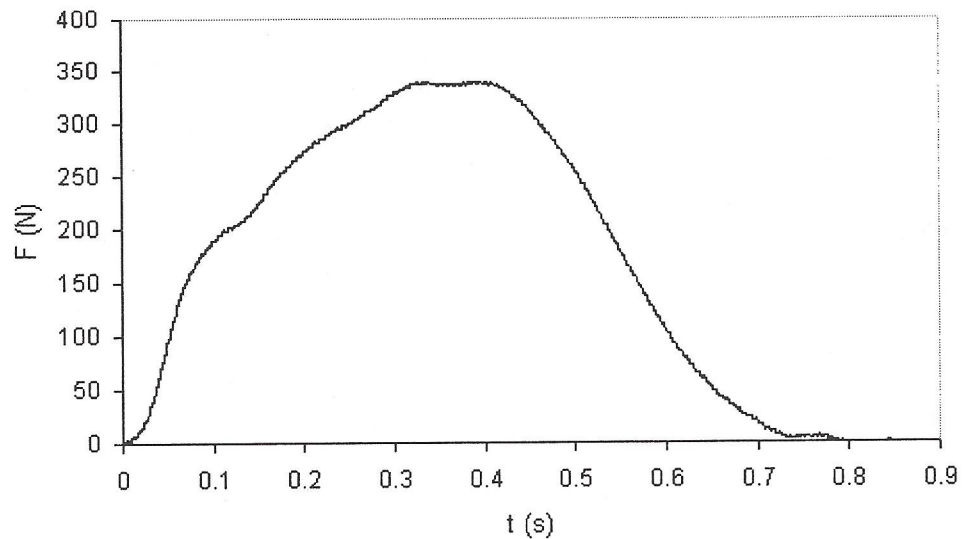

Figure 7 Typical thrust profile for AR-1 Rocket motor

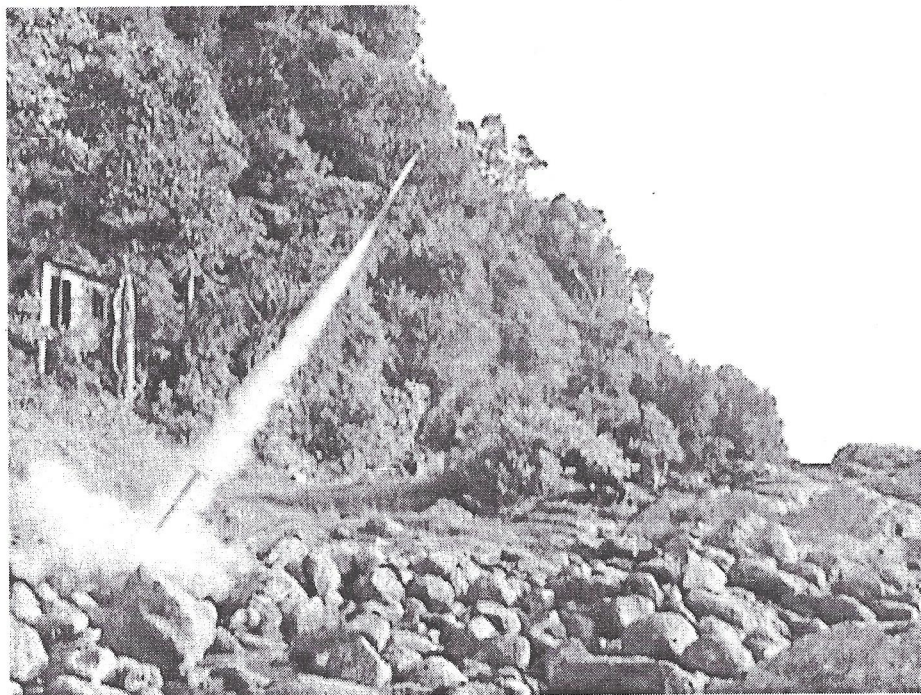

Figure 8 LAYANG-1 lift off

#### 4.0 CONCLUSION

The experiments conducted at UTM show that the KS propellant has the potential of reaching the necessary range for cloud seeding (1.7 km to 2.8 km). The advantages of KS propellant are low raw materials cost, and ease of handling,

processing and transporting. The propellant is safer, non-toxic, stable and produces non-toxic gases during firing. In conclusion, it can be said that Malaysia is capable of developing launch vehicle propulsion system for small vehicle such as launch vehicle for cloud seeding.

### ACKNOWLEDGEMENT

The authors are grateful to the Ministry of Science, Technology and Innovation of Malaysia for supporting this work under IRPA grant (project no: 09-02-06-0256) and Universiti Teknologi Malaysia for the facilities and human resources.

### REFERENCES

1. Cornelisse, J.W 'Rocket Propulsion and Spaceflight Dynamics', Pitman, London, 1979
2. Barrere, M. et. al, 'Rocket Propulsion', Elsevier Publishing Co, Paris, 1960
3. Kit, B and Evered, D.S, 'Rocket Propellant Handbook', The MacMillan Co, New York, 1960
4. Fordham, S, 'High Explosives and Propellant' Pergamon Press, Britain, 1980
5. Mohd. Jaafar, M.N. et. al 'Pengaruh Kaedah Penyediaan/Fabrikasi Propelan ke Atas Kadar Pembakaran', *Proc. of National Seminar on Advanced Materials Development in Malaysia*, Johor Bahru, pp 12-15, 2001
6. Mohd. Jaafar, M.N et al, 'Performance of Potassium Nitrate as Solid Propellant', *Proc. of 6<sup>th</sup> Asia-Pacific International Symposium on Combustion and Energy Utilization*, Kuala Lumpur, 2002.
7. Renganathan, K. et. al 'A Multilayered Thick Cylindrical Shell Under Internal Pressure and Thermal Loads Applicable to Solid Propellant Rocket Motors', Springer-Verlage, Germany, 2000
8. Morell, V. E 'Effect of Combustion-Chamber Pressure and Nozzle Expansion Ratio on Theoretical Performance of Several Rocket Propellant Systems', NACA Research Memorandum, RME50C30, Washington, 1950
9. Dunn, S.S & Coats, D.E, 'Nozzle Performance Predictions Using the TDK 97 Code', AIAA 97-2807, USA, 1997
10. Barrere, M. et. al, 'Rocket Propulsion', Elsevier Publishing Co, Paris, 1960

