

APPLICATION OF TOTAL PRODUCTIVE MAINTENANCE (TPM) CONCEPT IN PALM OIL MILL FACTORY

Muhamad Zamari b. Mat Saman
Pang Chee Wai

Department of Manufacturing and Industrial Engineering,
Faculty of Mechanical Engineering,
Universiti Teknologi Malaysia,
81310 UTM Skudai, Johor, Malaysia.
(E-mail: zameri@fkm.utm.my)

ABSTRACT

This study is about the application of total productive maintenance (TPM) concept in a palm oil mill factory. The objective of this paper is to highlight the advantage of TPM concept and to increase the operating efficiency of equipment recognized as the overall equipment efficiency (OEE) on shop floor. In consequence this should bring benefits to the particular factory. A case study was carried out in a palm oil mill factory to investigate existing situation. Pilot equipment was selected to serve as a target for TPM implementation in improvement prioritization analysis. In consequence, a list of all possible causes of losses was established and countermeasures to eliminate losses were recommended.

Keywords: *TPM, OEE, First Pilot Equipment, Availability, Performance Rate, Quality Rate, Losses, Autonomous Maintenance.*

1.0 INTRODUCTION

Equipments or machines in production floor would often encounter breakdowns; stop for repair or parts replacements and quality defect were considered common to manufacturing industry. Each one of them is important to achieve high productivity. Any breakdown or malfunction would affect some resources such as time, material and energy, thus cause an increase of operating and maintenance expenses in manufacturing industries [3]. A method is forthcoming for industries to use that could reduce or eliminate the breakdown or malfunction problems. The method should have the characteristics to reduce the frequency of breakdowns, frequency of repair and capable to attain high performance and high efficiency level of production equipment that would improve plant productivity. Total productive maintenance (TPM), is a powerful shop floor management philosophy that is expected to react as a plant improvement tool that could maximize the effectiveness of equipment and increase profit simultaneously [6].

Basically, TPM is not only concerned about machinery maintenance, but also involves operational procedures, equipment installation and co-operation between production and maintenance departments, equipments modification (innovation)

and the involvement of employee [2,7]. It enables continuous and rapid improvement, through the employee involvement and empowerment (from the traditional reactive to pro-active attitude). As a result, smart exploitation of TPM philosophy will gain competitive advantages in business.

2.0 PROBLEM IDENTIFICATION

2.1 Background

First of all, an overall observation study has been carried out in a production shop floor of a palm oil mill company. In order to reduce the scope of the entire production shop floor, there are few types of equipments which were more vital and more often encountered malfunctioning compare to the residual equipments have been chosen to collect data for comprehensive OEE analysis. This approach resembles closely to the machine "Failure Mode and Effect Analysis (FMEA) whereas to rank the equipment improvement priority followed by their occurrence of problem, severity and likelihood of detection. Four types of equipments, namely the thresher, digester, twin-screw press and vibrating screen have been selected for TPM consideration.

The data required for each equipment are loading time, down time, ideal and actual capacity and defect rate. Based on these data, the availability, performance rate and quality rate of each equipment could be acquired and the subsequent analysis of OEE level could also be done. Once the OEE level of each equipment has been figured out, a candidate list and rank for determining the priority to be improved for the equipment were obtained. Thereafter, the first priority equipment will be defined as a first pilot equipment, which is selected to eliminate the losses of itself in the project and then the one after it would be followed to the result of the candidate-ranking list.

2.2 Data Collecting (Thresher, Digester, Twin Screw Press & Vibrating Screen)

A case study on the production shop floor of a palm oil mill company was conducted and some data have been collected with the purpose to measure the OEE level of each equipment as shown in Table 1, 2, 3 and 4.

Table 1 Operational Data of Two Threshers

Types of Thresher	A	B
Monthly down time (hours)	11	12
Stripping efficiency / quality (%)	92	88
Design speed (RPM)	26.0	26.0
Actual speed (RPM)	25.1	24.9

Table 2 Operational Data of Six Digesters

Types of Digester	A	B	C	D	E	F
Monthly down time (hours)	16	23	35	14	14	26
Ideal capacity (ton/ hour)	15	15	15	15	15	12
Actual capacity (ton/ hour)	13.6	13.0	13.2	13.8	13.4	10.8
Oil Loss (% W.B.) out of 45 % W.B.	1.0	0.8	0.8	1	0.4	0.6

Table 3 Operational Data of Six Twin Screw Press

Types of Press	A	B	C	D	E	F
Monthly down time (hours)	68	61	74	68	88	95
Ideal capacity (ton/ hour)	15	15	15	15	15	12
Actual capacity (ton/ hour)	13.6	13.0	13.2	13.8	13.4	10.8
Oil Loss (% W.B.) out of 45 % W.B.	2.1	3.2	3.3	2.5	3.8	3.4

Table 4 Operational Data of Two Vibrating Screen

Types of Vibrating Screen	A	B
Monthly down time (hour)	18	24
Designed Amplitude of vibrating Screen (mm)	27.5	27.5
Actual Amplitude of vibrating Screen (mm)	26	26
Ideal ratio of oil purity	65:68	65:68
Actual ratio of oil purity	61:68	63:68

2.3 Overall Equipment Effectiveness (OEE) Analysis Result

After sufficient data have been collected, the measurement of OEE for each equipment could be initiated. The purpose of measuring the OEE is to have clear knowledge about the current plant's conditions, OEE is a TPM indicator, that is developed to help evaluate the equipment performance. Without evaluating the OEE of each equipment, the truth about the seriousness of the equipment condition would never be realized especially if a plant has a large number of equipments. The measurement comprises three variables namely availability, performance and quality rate as shown below,

$$\text{Availability, } A = \frac{(\text{Loading time} - \text{Unplanned downtime})}{\text{Loading time}} \times 100 \%$$

$$\text{Performance rate, } P = \frac{(\text{Processed amount} \times \text{Ideal cycle time})}{\text{Loading time}} \times 100 \%$$

$$\text{Quality rate, } Q = \frac{(\text{Total parts run} - \text{total defects})}{\text{Total parts run}} \times 100 \%$$

$$\text{Thus, } \% \text{ OEE} = A \times P \times Q$$

The formulae above show the basics of measuring OEE level from the collected data. Therefore, the % OEE for the four types of equipment could be obtained as follows:

- i) % OEE of 2 Thresher
 - a) $97.7\% \times 96.54\% \times 92.0\% = 86.77\%$
 - b) $97.5\% \times 95.77\% \times 88.0\% = 82.17\%$
 - Average % OEE = 84.47%
- ii) % OEE of 6 Digester = $95.58\% \text{ (Average)} \times 89.40\% \text{ (Average)} \times 98.28\% \text{ (Average)}$
= 83.98%
- iii) % OEE of 6 Twin screw press = $84.37\% \text{ (Average)} \times 88.52\% \text{ (Average)} \times 93.24\% \text{ (Average)}$
= 69.63%
- iv) % OEE of 2 Vibrating Screen
 - a) $96.25\% \times 94.54\% \times 93.84\% = 85.39\%$
 - b) $95.00\% \times 94.54\% \times 96.92\% = 87.04\%$
 - Average % OEE = 86.22%

These % OEE values may be very useful as a measure of quantitative reference for improvement activity efficiency estimation and also play a crucial role in the improvement prioritization analysis in the coming section.

2.4 Select First Pilot Equipment

From the previous OEE calculation of each equipment, a condition or efficiency of each equipment was compared. From the calculation, the twin-screw press shows the worst problem. From here, the equipments can be selected for remedial action by the implementation of TPM procedure.

In this part, prioritization of equipment candidates which to be the first to kick off the TPM implementation is decided by the priority as shown in Table 5.

Table 5 Prioritization analysis of the four equipments on the shop floor

Equipment Candidate List				
Equipment candidate for performance elevation	Criticality ¹	Effectiveness losses ²	Degree of difficulty for improvement ³	Priority result ⁴
Thresher	2	3 (84.47%)	4	2 x 3 x 4 =24
Digester	3	2 (83.98%)	3	3 x 2 x 3 =18
Twin screw press	1	1 (69.63%)	2	1 x 1 x 2 =2
Vibrating screen	4	4 (86.22%)	1	4 x 4 x 1 =16

- 1 smallest number indicate the most importance equipment
- 2 the smallest number represent the worst condition's equipment
- 3 the smallest number indicate the easiest situation to be improved
- 4 the smallest number represent the first priority

As shown in Table 5, the first equipment to execute the performance elevation is twin-screw press. The criticality of each equipment should be thoroughly evaluated by the company's upper management personnel. It was agreed that setting the screw press as the most critical equipment for the oil extraction process. The highest losses of OEE equipment would be ranked to smallest number, which the press also recognized as smallest number. The degree of difficulty expressed the degree of toughness to improve the performance of the equipment, which the vibrating screen had the easiest potential to be improved. The experienced maintenance expert and engineers are judging this criterion by their profession sight.

2.5 Justification of Process OEE Correlation to Financial Results

From the previous analysis, the effective availability for the sub-process was the availability of twin screw press calculated at 69.63%. Besides, the actual constraining operation equipment of the process was also twin-screw press which having availability of 84.37% (weighted average). The quality of the process is measured as follows

$$\begin{aligned}
 \text{Total parts run (full amount of oil W.B.)} &= 100\% \\
 \text{Defects of constraining operation (press)} &= (100\% - 93.24\%) \\
 &= 6.76\% \\
 \text{Defects of downstream (vibrating screen)} &= (65/68 - 61/68) + (65/68 - 63/68) \div 2 \\
 &= 4.41\% \\
 \text{Quality rate for Process} &= \frac{100\% - 6.76\% - 4.41\%}{100\%} \times 100\% \\
 &= 88.84\% \\
 \text{Therefore, Process OEE (comprised of 4 sub-process)} &= (0.8437 \times 0.8852 \times \\
 &\quad 0.8884) \times 100\% \\
 &= 66.35\%
 \end{aligned}$$

Up to here, there are still few data needed to complete the correlation of this process to the financial result. They are shown as below (all the prices are subjected to market changes which the price of finish crude palm oil fluctuate from RM 1250 per ton to RM 2100 from last year to this year, the suitable assumption = RM1400 per ton),

- i) Raw (with bunch stalk) FFB Cost (RM/ton) = 350
- ii) If assume there are 65% of raw FFB were fruits,
the cost of fruits (RM/ton) = $350 \times 100/65$
= 538.46
- iii) Press crude oils value (RM/ton) = assume 50 % of finish C.P.O
(after 4 sub-process) = $0.5 \times \text{RM } 1400$
= RM700
- iv) Total added value of the process (RM/ton) = $700 - 538.46$
(after 4 sub-process) = RM161.5

Considering the total cost expenses on the sub-process assumed that net revenue equals to the 35% of the sub-process added value.

- v) Profit added value (RM/ton) = 161.5×0.35
= 56.525

1 hour may produce 50 tones, it mean in one hour the profit added value
= 50×56.525
= RM2826.25

Known the process (4 sub-process) OEE value = 66.35%, assume the 6 big losses represent $(100\% - 66.35\%) = 33.65\%$.

Therefore, the total profit deduction (from 6 losses) = $\text{RM } 2826.25 / \text{hour} \times 33.65\%$
= RM951/ hour

In one year, assume the total working days = 310 days
Thereupon, the total yearly operating hours = 310×16
= 4960 hours

Annual profit deduction = $4960 \text{ hour/ year} \times \text{RM } 951/\text{hour}$
= RM4916960 per year (33.65% losses)

Therefore, 1 % improvement of OEE = $\text{RM}4916960/33.65\%$
= RM140,177

The analysis make sense of 1% improvement of Process OEE will be bringing back RM 140, 177 to the company according to all assumptions which have been earlier stated. Somehow, as logically approximation, the figure is reliable.

3.0 CAUSES ANALYSIS OF PILOT EQUIPMENT LOSSES

After the first pilot equipment has been selected in previous section, the downstream discussion will be focused on the twin-screw press, which is to be the chosen target of TPM implementation. The causes analysis will be began from the losses investigation according to the availability, performance rate and quality rate respectively to that particular equipment. There were few approaches or quality improvement tools could be used such like Pareto's law, fault tree analysis, fish bone diagram and 5W-1H (Why, When, Where, Who, Which and How) [1,4,5].

3.1 Causes Analysis Of Availability Losses

There are few significant causes that may led the breakdown of twin screw press,

- i) Exist of foreign material.
Normally there are some foreign materials fall together with the fruit bunches at loading ramp. Such as stone, fragments of iron, screw, iron rod etc. These materials were too hard to be crashed and pressed by screw press. This was known as the major causes of breakdown because this factor might affect serious breakdown of this equipment.
 - (a) The production of thrust force from foreign material.
It would result the worse abrasion of core shaft and bearing, broken of key-way between screw and the core shaft, slipping of bearing and some time cause the displacement of press set and drive shaft which results in misalignment problem.
 - (b) The mechanical impact or collision could deteriorate the related parts such as gearbox and sprocket that attached with the press set when the worm screw is suddenly jammed because of hard solid.
 - (c) Overload of press because the press unable to press or crash the hard material.
 - (d) The contents of such foreign materials will produce friction with worm screw, press cage and cone adjuster, thus shortened the life span of these components.

ii) The ignored of operating ampere fluctuation with hydraulic pressure which may brought such failure modes as below,

- (a) The wide range variation of force may cause misalignment and influence the overall mechanical fitting specification gradually, thereby could result in long-term serious deterioration.
- (b) The excessive force that produces by hydraulic may cause abrasion of worm screw, shaft, roller bearing; whole press set and damages the edge of key-way.
- (c) The fluctuation of press force may shorten the life of belt and motor.

iii) The lack of lubrication and inspection will have such consequences.

- (a) The raising of temperature dramatically by metal friction because of lacking of lubricating oil. When the mechanical component operated in the overheating condition (without lubricants), the mechanical parts can be worn out easily. As example: wear of bearing, housing, abrasion of shaft, damage of spur gear etc.
- (b) The characteristic changing of lubricant was another factor because when it had been expired from consumption duration or having of contamination, however if still holds using of it, it would fail to present the lubricating function.
- (c) The leakage of oil will cause those prior problems would never ever be solved.

iv) The improper installation

This is including of dismantling, refitting and replacing would frustrate the normal operating condition of equipment. Except the installation method, the wrong tool utilities that used the wrong tools for intended function will slow down the work rate. However, the most important thing is it may cause the incomplete work, which resulted less of over tightening, spoiling or scratching the parts and oil leakage etc.

v) The non-conformance of material

Every mechanical component has its designed specification to do mechanical job. If the procured materials such as shaft and bearing have incorrect fits and tolerance, it would be worn out easily when using of it in operation or otherwise it may cause the damages of others related part. Sometimes the company did not keep the components in desired usage condition that cause rusty and contamination in those mechanical components. The dirty and messy environment around the equipment is also a reason to be blamed because it provides the equipment chances exposed to the contamination.

3.2 Causes Analysis of Performance Rate Losses

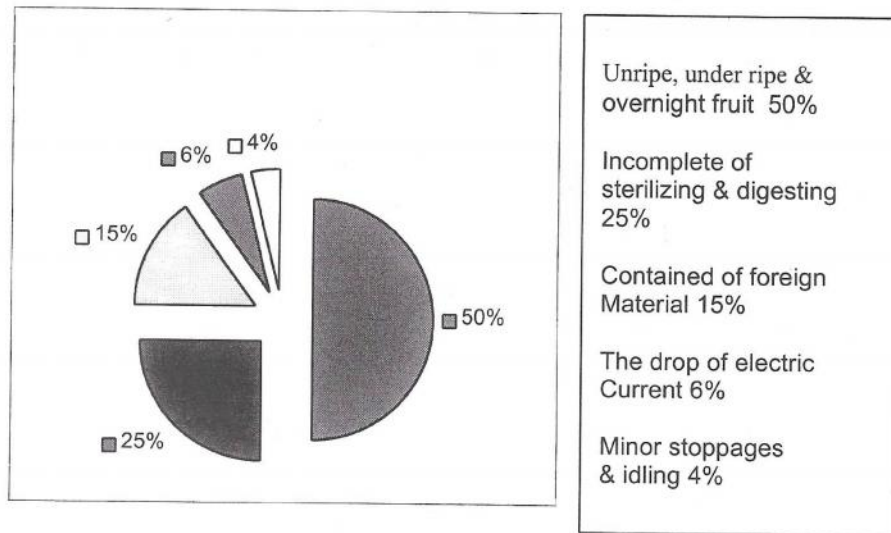

Figure 1 The factors affected losses of performance

Figure 1 in shows some factors, which influence the performance rate of pilot equipment. Some how, the main factor unripe fruit was not covered by TPM implementation, thus the causes analysis would only considered the residuals.

The second factor which may reduced the performance rate was incomplete of sterilizing and digesting process. Those defects will make the fruit become harder than ordinary fruits, which caused speed, reduced similarly to unripe or overnight fruits. The main cause of this factor was evolved from the incorrect steam supply from boiler. The boiler of company is designed to operate at 280 (psi) or equally with 1.9 MPa. However, from the past records of the company it is known the boiler only produced steam fluctuating at the 220- 260 psi. As a result the pressure supply to the sterilizer would be insufficient. This will affect the result of sterilizing dramatically. It becomes worse when the steam passes through the delivering piping system, which leaked.

Again, the fruit mass which contained hard foreign material and when it pressed by the worm screw, high friction will be produced. Then, the friction resist the mechanical works and so the speed. The dropped of electric power supply, also should be blamed of inconsistency of steam supply. Finally the idling and minor stoppage is because of those previous causes and proportional to them. Beside this, there is something, which was unavoidable to have minor stoppage during operation.

3.3 Causes Analysis of Quality Rate Losses

Due to the quality rate level of pilot equipment, it was a very fair or satisfactory figure with 93.24%. Basically there are impossible to achieve 100% of quality

rate because of the losses from evaporation, viscosity and some others physical science restricts. Therefore, there will be no further suggested countermeasures for the improvement of quality rate. Usually any palm oil mill company would give 5%-9% of allowance to quality losses. Finally it is shortlisted to 7 causes of losses.

- i. Exist of foreign material
- ii. The ignored of operating ampere fluctuation
- iii. The lack of lubrication and oil inspection
- iv. The improper installation
- v. The non-conformance of material
- vi. Incomplete of sterilizing process
- vii. Fluctuation of Steam pressure

4.0 COUNTERMEASURES TO LOSSES FOR PILOT EQUIPMENT

The following are the countermeasures suggested to control losses for pilot equipment. While these measures have not been proven in this paper, they can nevertheless be used for guidance at palm oil shop floors that encounter similar problems. Besides, from the TPM viewpoint, the countermeasures are implemented as small group activities to obtain better results of improvement.

4.1 Existance of Foreign Material

- i) Correct the design weakness of the twin-screw press (under 5th pillar of TPM: MP design and early equipment management). For instance, the magnet could be use to attract and stick the metal fragments. Before the fruit lets get into screw press its need to pass along the conveyor. Therefore, a very strong permanent magnet bar may fix at the surface of iron chute (a slope drain to lead the fruit lets shift to another conveyor), as shown in Figure 2.

It is designed to install a sensor simultaneously that when the metal fragment adhere to the plate, the signal of sensor will be activated and after the operator aware of it, he could take it out of the drain by open the designed special door.

- ii) It should be planned to do initial cleaning envelope the work place (2nd pillar of TPM). This action is aimed at clear up of those metal fragments that presented everywhere in the shop floor. Especially the area that easily to get mixed with the conveying fruit lets. Setting up of scheduled cleaning task table can do this to the operators.

Provide education to operators (4th pillar of TPM concept) that let them know the consequence of the hard material when mixed into fruit let and change their attitude to keep cleanliness of the work place. The main purpose of this action is to prevent the re-polluted of metal scraps and metal components after effort of initial cleaning from prior actions. This

countermeasure should be covered the entire organization that be aware for the issues of foreign materials.

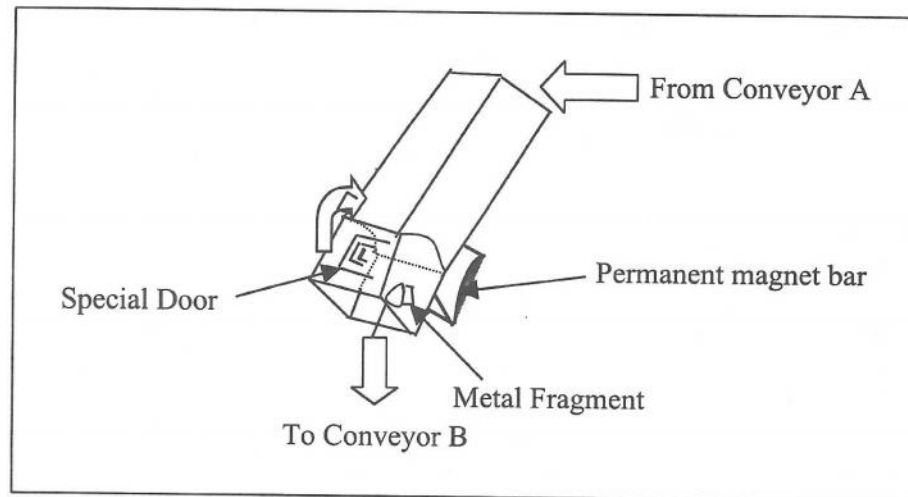

Figure 2 Proposed improvement action of design weakness

4.2 The Ignored of Operation Ampere Fluctuation

This is merely human-error problem and it should be emphasized to the operators themselves. The proposed countermeasures are as below,

- a) Enhance education and training to operators. Perhaps, the operators may not know how importance of the effects of the operating ampere fluctuation to the normality of equipment conditions. Thereby, conducts a comprehensive training courses are beneficial to employees and company itself. Through the training, their knowledge and skill to operate the equipment could be enhanced by thoroughly and proportionally the increasing of company's productivity will be fairly compensate to the expenses for education activities.
- b) Correct the weakness of the design by fixing an automatic controller to the hydraulic resistor, which functioned adhering with the operating ampere. In long-term view, this action is very cost-effective to be carried out.

4.3 The Lack of Lubrication and Oil Inspection

From the TPM convention, this problem was appropriately to solve by introduce an autonomous maintenance task. Operators are the persons who closest to their machine, they are the one who were most suitable to carry out those routine simple maintenance jobs. Therefore, the company should conduct training of maintenance activities to the operators to keep the equipment always are in the normal usage condition. One of the important characteristics of machinery usage

condition requirement is lubrication. Some catastrophe defects may happen because of the operator's attitude and insufficient knowledge about lubricating among them. By the suggested of autonomous maintenance education launching to the operators, it is believed this problem would be easier to avoid form reoccur again. Especially, setting up standards of lubricants for equipment was actually a main activity of autonomous maintenance, which has 7 proposed activities. Certainly, in this context, it is advised the company to be paid for extra effort and contend of operators against the autonomous maintenance task.

4.4 Improper Installation

Before any improvement plan was generated, the reason of making mistake or improper installation should investigate. The reasons were two; first it was the attitude of maintenance personnel that did not serious in fixing mechanical part, never exanimate carefully and laxative to ensure the normality of equipment to perform the job. Secondly, they were insufficient of knowledge and often misunderstanding about the equipment. They did not know that in fact their method was not correct and inappropriate with the mechanism of operation. Due to these two reasons we could eliminate this problem by conduct technical training to increase the knowledge and maintenance skill, then followed by fostering of serious working attitude upon the maintenance personnel by introduce some incentive schemes which to be practiced on disciplined working environment.

4.5 The Non-Conformance of Materials

This problem was appropriate to remedy by used of early equipment management and MP design. In fact, there are 2 types of non-conformance of the materials in this problem. Firstly, sometimes the specification desired for usage condition did not met because the problem of vendors of manufacturer. Secondly, the company did not keep the spare parts in proper condition and make used of the spare parts that had been out of ordered.

It was necessary to launch early equipment or parts management to correct the problem of non-conformance. Regarding to the first non-conformance, the company should provide specification examination before accept the procured material in stand-by status which prepare to use. The company should assign one or two experience and skillful specification inspectors which inspect whether the fits (tolerances), types of equipment, brand, size, types of material and such others specification required were right or not. Meanwhile the second non-conformance problem was the faults of maintenance department, which stored the spare parts in poor conditions. Company must be emphasized on the reliability, functionality of that used part than too safe the cost blindly. It is not cost effectively in terms of small amount cost savings but resulted a great of others losses expenses. The maintenance department should be educated the importance of proper storing of components and then conduct the method of components caring.

4.6 Incomplete Sterilizing Process

The incomplete sterilizing process was due to the fault of operators whereas they are operating the sterilizer improperly. Therefore, in order to overcome the problem, again, the education program should be established to train the operators in the standard sterilizing process procedure with right regulations. In such a case, let the operators know the objectives of doing sterilizing and guide the operators through the demonstration was one of best way to prevent the operators making of mistake again during the operation. By using of single point lesson, it is to introduce once again to enlighten the operators which having high understanding of operating method. Besides, the incentive program encouragement could be practiced in this circumstance.

There was another problem that may lead to the incomplete of sterilizing. It was the leaking of steam pipe which cause the dropped of steam pressure and effected the normal conditions of sterilizing. Therefore the steam pipe and valves should be inspected frequently. The roles are suitable to act by maintenance personnel as a planned maintenance activity, which is known as preventive maintenance (PM).

4.7 Fluctuation of Steam Pressure

The pressure of steam may be fluctuated because of few defects. The most crucial defect was the leakage of steam in somewhere. The steams were delivered from boiler to turbine, and steam receiver which past several valves and then sent to the equipment such as digester, sterilizer and nut silo. Any leakage exist along the way may led to the defect. Secondly, if the water treatment process was not produced the boiler water successfully (right amount of desired mineral dissolved, gases, pH and moisture), there might be came after of few problem. The wall of water tubes and steam drums could be eroded and cause oxidation, pitting that will influence the pressure of the steam during generating of steam. Thirdly, the boilerman operated the boiler with some mistakes. According to the boiler-operating standard, there are maximally to blow the condensed steam in mud drum twice an hour, however in the company due to certain constraints they are blowing 4 or 5 times an hour. This will be resulting the dropped of pressure dramatically.

Therefore, it is suggested the following countermeasures,

- i) By pursuing an autonomous maintenance, which the boiler's maintenance, cleaning, and inspection are done by the boiler department, staff themselves with assistance of the engineers. This is because they are most understood to the real condition and circumstances in boiler operating, thus they are the best fit in doing maintenance task for boiler. Due to the defined problems as above, the majority of it was resulted from the overlooked of boiler's operators and more specifics from the work's culture. It is right to start changing their attitude by introduce the autonomous maintenance to them that they doing maintenance task for their equipment and fostering their habit to "love" their equipment or department. Therefore, a thoroughly plan to carry

out the autonomous maintenance should be established before the implementing of autonomous supervision.

- ii) In accordance with the autonomous maintenance concept, boiler's operator implements the planned maintenance activities in the department of power plant. There are real practicing of planned-well maintenance task in this case such as periodic inspection, adjustment, cleaning, lubrication, setting adjustment, parts replacing and any corrective action due to the solving of the problems. This is aimed to the prevention of the problem occurrences rather than to solve the problem temporary.
- iii) The previous 2 solutions are aimed at equipment perspective meanwhile the education is aimed at human perspective. From the training it is hoped that the boilerman would achieve high level of operating skill and knowledge with cautious and confidence mind. Another thing is to foster up the new attitude that always be taken action prior to the occurrence of malfunction and always think that all the existing losses is able to be removed if intending to do.
- iv) The welfare of boiler's stuff should be reinforced as encourage them to present the suggested solution. By introducing of the incentive schemes, the stuff would much rather easier to be motivated. It is believed, the prior efforts can works only by attracting the stuff by those suitable incentive such as annual leave, bonus, allowance, gift and especially high assurance of life if any accident happen at this hazardous area (insurance). Besides the materialistic encouraging, the commendation must be never absence because that complimentary word was also an effective tool of motivation.

5.0 CONCLUSION

This project has shown the developing of TPM concept for palm oil mill factory, which is, bring benefits and advantages to the factory especially in achieving OEE target. From the analysis of process OEE (4 sub-process), it is concluded that the improvement of 1% OEE of that particular process, the factory will be gaining back the returns of about RM140,177. This denoted one of the virtual benefits of TPM program besides of OEE and direct cost saving.

REFERENCES

1. Davis. R. K. (1995), *Productivity Improvement Through TPM*, Prentice Hall, London.
2. Nakajima, S. (1988), *Introduction to TPM*, Cambridge Productivity Press Inc.

3. Robinson, C. J. (1995), *North American Experience In TPM Implementation*, Portland Productivity Press Inc.
4. Shireo, K. (1992), *TPM For Supervisor*, Portland Productivity Press Inc.
5. Shireo, K. (1995), *TPM Team Guide*, Portland Productivity Press Inc.
6. Tajiri, M. (1992), *TPM Implementation: A Japanese Approach*, Mc-Graw Hill, USA.
7. Wireman, T. (1992), *Inspection and Training for TPM*, New York Industrial Press Inc.

