

ACTIVE FORCE CONTROL APPLIED TO A RIGID ROBOT ARM

Musa Mailah

Department of Applied Mechanics
Faculty of Mechanical Engineering
Universiti Teknologi Malaysia

J R Hewit
Sheik Meeran

Department of APEME
University of Dundee, United Kingdom

ABSTRACT

The paper presents the implementation of Active Force Control (AFC) strategy to control a rigid robot arm. The robustness and effectiveness of AFC as 'disturbance rejector' is demonstrated through a simulation study using MATLAB[®] and SIMULINK^{®} software packages. The work is carried out on a rigid two link planar manipulator experimenting with a number of external disturbances. The results are directly compared to an equivalent system which employs the conventional model-based Proportional-Derivative (PD) control method.*

1.0 INTRODUCTION

As the tasks of the robotic application are becoming more complex and challenging, the motion and force control of an arm is a vital consideration in designing a robotic system. The classical PD control [1], though structurally simple and relatively stable could only provide satisfactory performance at relatively low speed operations. At high speed, the performance degrades considerably due to system dynamics and friction (disturbances). There is also a problem of tuning of the

controller gains to achieve optimum performance of the controller. The model based computer torque control [2] method provides refined performance but again at higher speeds, the performance is severely affected. A major drawback of the model based control method is that it requires the exact knowledge of the physical system with respect to its dynamics and kinematics – thus it is computationally intensive and time consuming. Adaptive control techniques have been proposed [3, 4, 5] and to a certain degrees succeeded in overcoming this problem – providing better performance and robustness in a wider range of system operating parameters but at the expense of involving complex mathematical manipulation. The implementation of the adaptive control method in real time poses a problem due to the complexity of the models involved and more often than not, most of the works are done through simulation. There is an emerging class of adaptive control methods better known as intelligent control which incorporates elements of neural network, fuzzy logic and artificial intelligence (AI). This intelligent control methods are increasingly being used in robotic systems [7-10]. Yet another type of control scheme, especially to cater for situation where the robot is in contact with the environment or subject to various forms of forcing, using a force/position control strategy has been established [11-13]. This method of control normally incorporates the model based and/or adaptive control feature in its strategy. Control of a rigid two link arm using one of these schemes, normally referred to as ‘active force control’ (AFC) as proposed by Hewit et al [12] is described in the early part of this paper. Then it goes on to present how this AFC scheme performs when different types of disturbances are encountered. Finally, the capability of AFC in countering the disturbances is compared with that of a conventional PD system.

2.0 AFC SCHEME

The mathematical formulation of the AFC scheme applied to a robot arm can be found in [12, 14]. A significant feature of the AFC method is that, a system may be subjected to any known or unknown disturbances acting on the system rendered ineffective by a compensating strategy which the method uses. In other words, the system remains stable even in the presence of the ‘noises’. Another advantage of the

AFC scheme is the ease of implementation in real systems [12, 16]. Figure 1 shows a schematic of the proposed AFC scheme which also include a model-based feature. The main AFC loop which is highlighted by the dashed line box, is explained in the following paragraph.

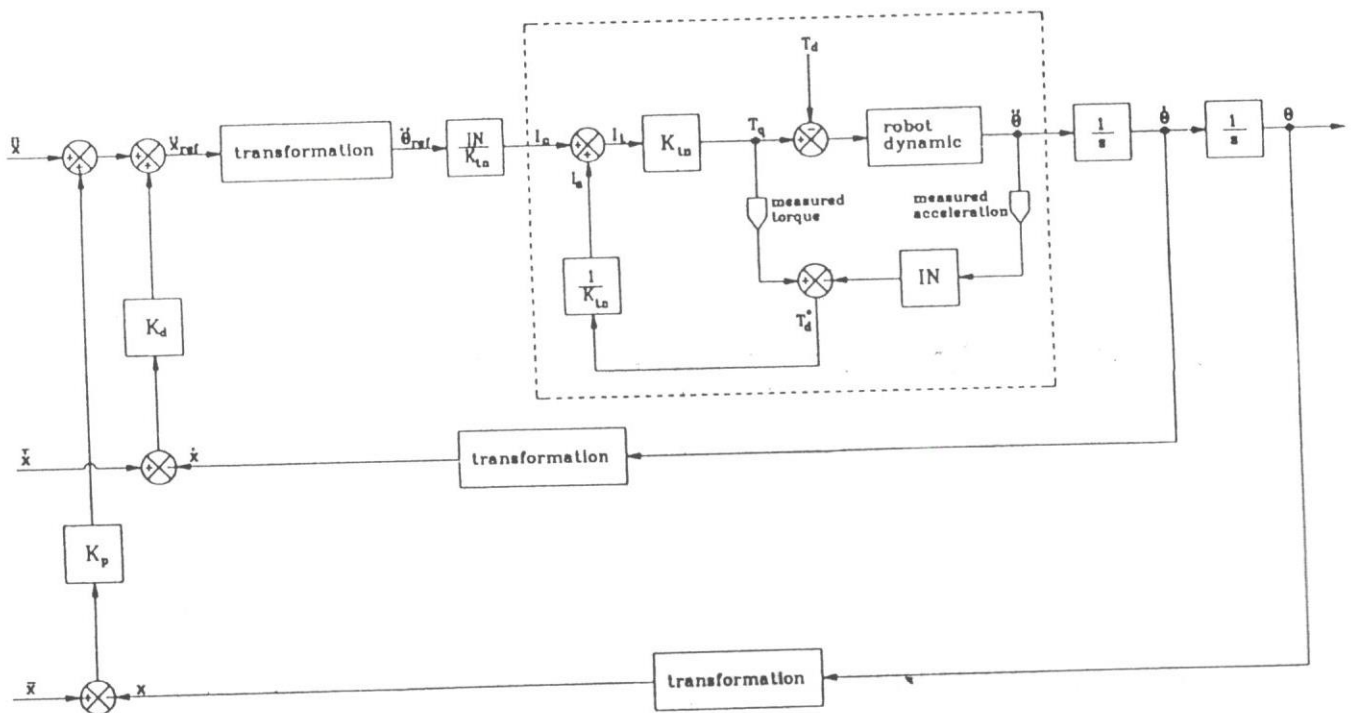

Fig. 1 A Schematic of the AFC Scheme

The AFC serves as a disturbance rejection scheme in which the disturbance T_d^* can be compensated in the feedback loop if the inertia matrix is well estimated. In order to estimate the inertia matrix, it is required to measure the variation in actuator forces (torques) and the acceleration which can be easily accomplished by means of using force sensor (or current sensor) and accelerometer. Hence the need for the exact mathematical model of the robot arm does not arise which in turn reduces the computational complexity involved in compensating the external disturbances. However, the stability and robustness can be improved by integrating a model based control with AFC.

As a mentioned earlier, the main requirement of the AFC scheme is the estimation of the inertia matrix, **IN** on which the basic function of AFC relies in compensating for the external disturbances. A number of methods has been proposed such as referring to a look-up table or even making crude approximation [14]. In this work, the crude approximation method is used to estimate the inertia matrix. However, estimation of the matrix becomes more challenging here since the system being considered is a two link arm which is highly non-linear and coupled. A number of experimentation has suggested that the scheme works effectively if **IN** chosen lies within certain bounds of the actual inertia matrix, **H** (derived from the dynamic model) of the robot arm. Hence, in this study, the value of **IN** is selected to be a proportion of the diagonal terms of **H**, i.e.

$$[\mathbf{IN}] = \mathbf{c} * [\mathbf{H}]$$

where *c* is a constant and a bound is chosen such that $0.4 < \mathbf{c} < 1.2$. The off-diagonal terms of the matrix are deliberately omitted for simplification.

3.0 MATHEMATICAL MODEL

The dynamics of the robot arm can be derived from the robot equation of motion using Newton-Euler method or the Lagrangian mechanics [17]. The general equation of motion of a robot arm (revolute type) can be described as follows:

$$\mathbf{T}_q = \mathbf{H}(\theta)\ddot{\theta} + \mathbf{h}(\theta, \dot{\theta}) + \mathbf{G}(\theta) + \mathbf{T}_d \quad (1)$$

where

- \mathbf{T}_q = vector of actuator torques
- $\mathbf{H}(\theta)$ = *N* x *N* dimensional manipulator and actuator inertia matrix
- $\mathbf{h}(\theta, \dot{\theta})$ = vector of Coriolis and centrifugal torques
- $\mathbf{G}(\theta)$ = vector of gravitational torques
- \mathbf{T}_d = vector of external disturbance torques
- $\theta, \dot{\theta}$ and $\ddot{\theta}$ = joint position, velocity and acceleration respectively

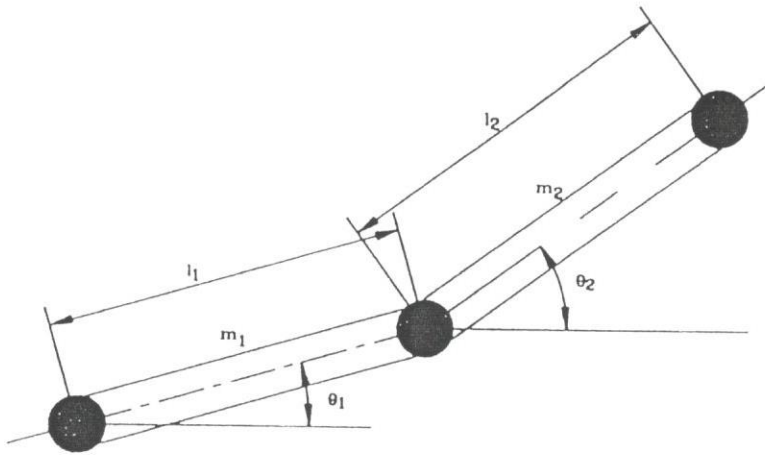

- l_1 : length of link 1
- l_2 : length of link 2
- θ_1 : joint angle of link 1
- θ_2 : joint angle of link 2
- m_1 : mass of link 1
- m_2 : mass of link 2

Fig. 2 A Representation of a Two Link Manipulator

For a horizontal two-link rigid planar manipulator as shown in Fig. 2, its dynamic model is given by,

$$\begin{aligned} T_{q1} &= H_{11}\ddot{\theta}_1 + H_{12}\ddot{\theta}_2 - h\dot{\theta}_2^2 - 2h\dot{\theta}_1\dot{\theta}_2 \\ T_{q1} &= H_{22}\ddot{\theta}_2 + H_{21}\ddot{\theta}_1 - h\dot{\theta}_1^2 \end{aligned} \quad (2)$$

where

$$H_{11} = m_2 l_{c1}^2 + I_1 + m_2 (l_{c1}^2 + l_{c1}^2 + 2l_1 l_{c2} \cos \theta_2) + I_2$$

$$H_{12} = H_{21} = m_2 l_1 l_{c2} \cos \theta_2 + m_2 l_{c2}^2 + I_2$$

$$H_{22} = m_2 l_{c2}^2 + I_2$$

$$h = m_2 l_1 l_{c2} \sin \theta_2$$

where

- I = mass moment of inertia of link
- m = mass of the link
- l = length of the link

l_c = length of link from the joint to the centre of gravity of link

The gravitational term of the general equation of motion of the arm has been omitted since the arm is assumed to move only in a horizontal plane.

For the AFC method, the control signal is given by,

$$I_c = \mathbf{IN}^* \ddot{\theta}_{ref} / K_{tn} \quad (3)$$

The compensated (absorbed) signal is

$$I_a = T_d^* / K_{tn} \quad (4)$$

and the applied torque vector,

$$T_q = K_{tn} * I_t \quad (5)$$

where

$\ddot{\theta}_{ref}$ = acceleration command vector

T_d^* = estimated disturbance torque

I_t = torque motor current, $I_t = (I_c + I_a)$

K_{tn} = torque motor constant

For pure PD control method, the following control law is assumed:

$$T_q = K_p(\theta_d - \theta) + K_d(\dot{\theta}_d - \dot{\theta}) \quad (6)$$

where

θ_d = desired joint position

$(\theta_d - \theta)$ = joint position error

$(\dot{\theta}_d - \dot{\theta})$ = joint velocity error

K_p and K_d = gain constants

4.0 SIMULATION

Simulation of the control schemes is performed using MATLAB[®] and SIMULINK[®] [The Math Works Inc. 1996] software packages on a 486 DX4 100MHz PC.

The simulation blok diagram for the AFC scheme can be seen in Fig. 3. It comprises a number of components and subsystems; the trajectory planner, model-based PD control section, AFC loop, robot dynamics model and the disturbance model. All of these are interconnected by means of connecting lines and the suitable building blocks acquired from the SIMULINK[®] library. The trajectory planner accommodates the prescribed and desired trajectories which the end effector has to follow as the arm moves via control algorithm. the model based section, i.e. the PD component provides the reference acceleration command (involving inverse kinematics of the robot arm) required for the control signal. This is fed into the AFC loop. It is in the AFC loop that the actual disturbance cancellation process is taking place assuming that both the acceleration and the torque vectors were suitably 'measured'. The 'measured' acceleration signal from the motor current-torque linear relationship. The dynamic model is directly derived from the mathematical equation describing the dynamics of a rigid two-link arm. The disturbance model incorporates a number of external disturbance torque models such as the constant applied torque, spring force and harmonic force in which the user is free to assume during the course of the simulation work. A combination of these disturbances is also possible. For pure PD control, the AFC loop and part containing the acceleration command vectors are omitted as shown in Fig. 4.

On-line viewing of any desired parameters is made possible by connecting the variables to the 'XY Scale Graph', 'XY Autoscale Graph' or 'Scope' blocks from the 'SINK' library in the SIMULINK[®] environment. Variables can be transferred to the MATLAB[®] workspace by means of 'to workspace' block. Once the program is started, the parameters can be viewed on-line via computer screen by simply pressing the 'hot' keys of the computer keyboard or from the pull-down menus. Any change of parameters can be accomplished by manipulating the

SIMULINK[®] blocks or the MATLAB[®] workspace. The parameters used in the simulation study are given as follows.

Robot parameters:

Link lengths,	$l_1 = 0.25 \text{ m},$	$l_2 = 0.2236 \text{ m}$
Link masses,	$m_1 = 0.3 \text{ kg},$	$m_2 = 0.25 \text{ kg}$
Motor masses,	$\text{mot}_{11} = 1.3 \text{ kg},$	$\text{mot}_{21} = 0.8 \text{ kg}$
Payload mass,	$\text{mot}_{22} = 0.1 \text{ kg}$	

Controller parameters:

For AFC control:

The controller gains,	$K_p = 750/\text{s}^2,$	$K_d = 500/\text{s}$
Motor torque constants,	$K_{\text{tm}} = 0.263 \text{ N/A},$	
AFC constants,	$K_c = 1.0$	

For PD control:

The controller gains,	$K_p = 700/\text{s}^2,$	$K_d = 2.5/\text{s}$
-----------------------	-------------------------	----------------------

Simulation parameters:

Integration algorithm	:	Runge-Kutta 5
Simulation time start, tstart	:	0.0
Simulation time stop, tstop	:	varies
Minimum step size	:	0.001
Maximum step size	:	1

The gain constants, K_p and K_d of the control schemes are assumed to be satisfactorily tuned prior the simulation work. The motor torque constant K_{tm} of the AFC scheme is obtained from the actual data sheet for a suitable dc torque motor, while the AFC constant K_c is deliberately set to 1 (100% AFC or full AFC) throughout the study. Simulation is performed first without considering any external disturbances acting on the system. Later, a set of applied disturbance torques are assumed.

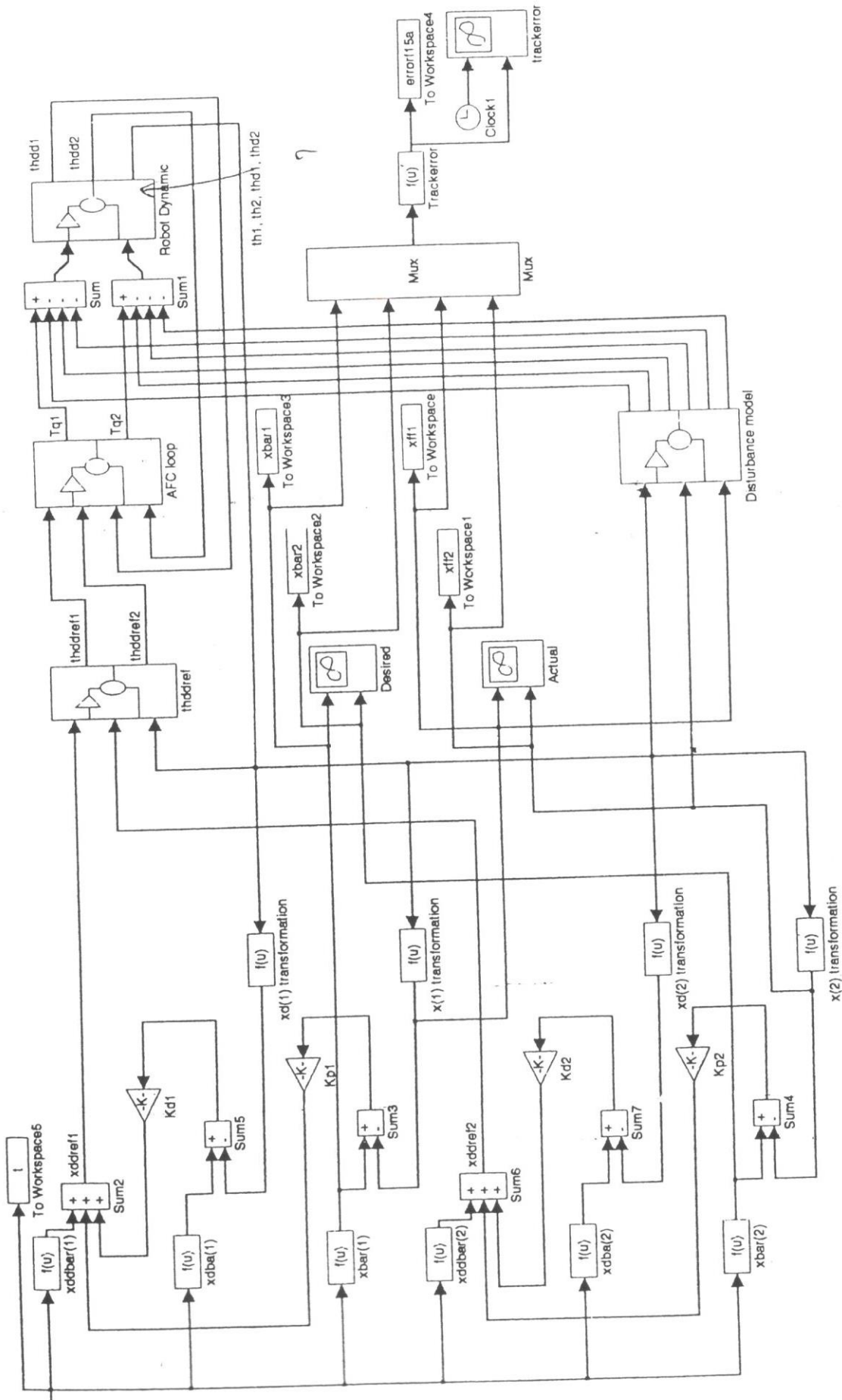

Fig. 3 SIMULINK Block Diagrams for AFC Scheme

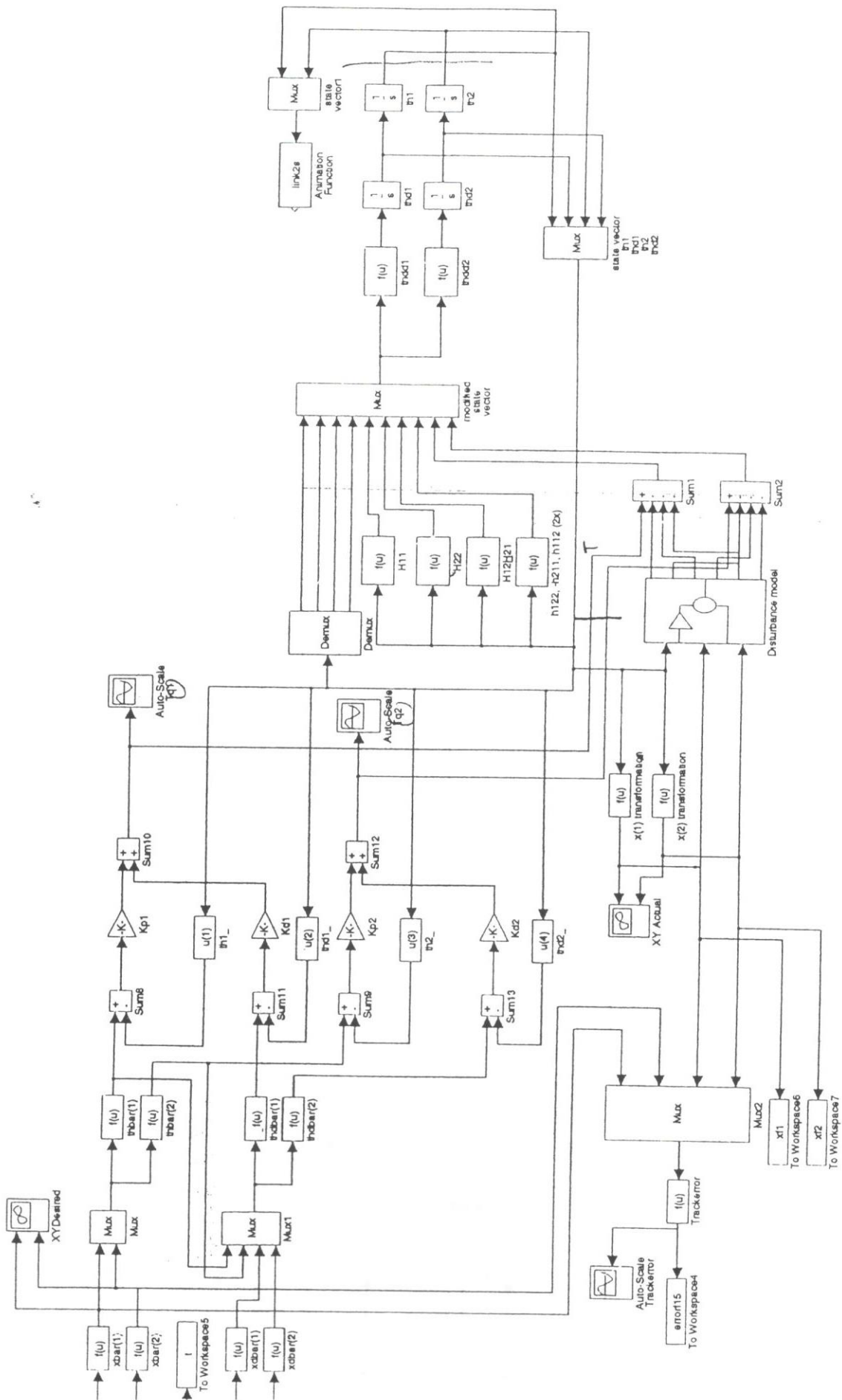

Fig. 4 SIMULINK Block Diagrams for PD Control Scheme

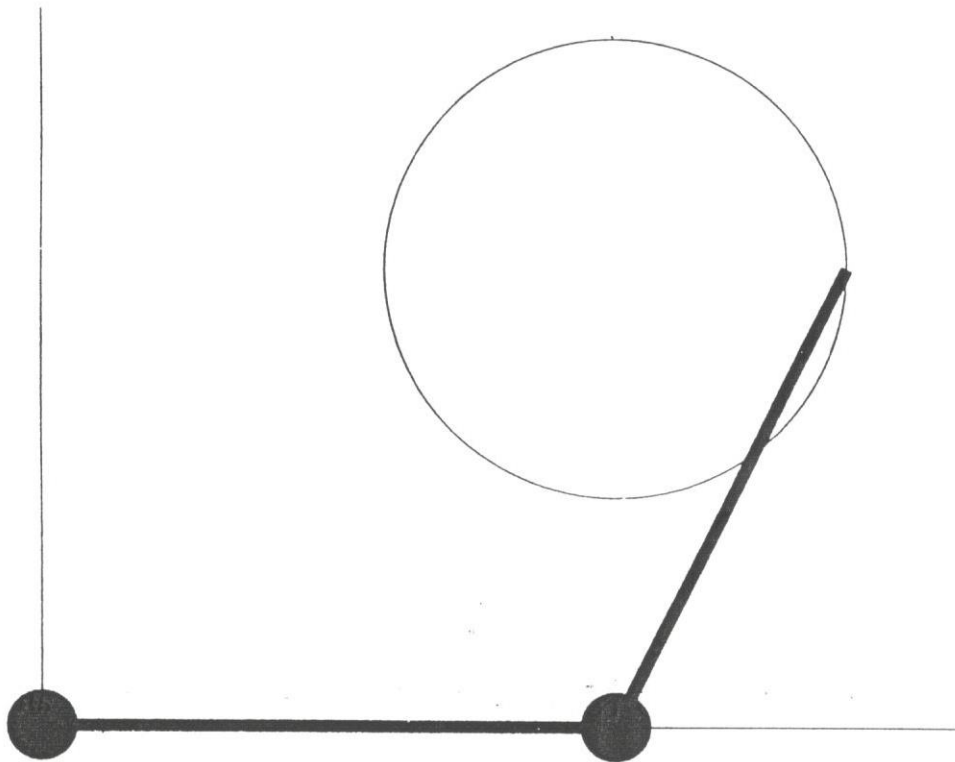

Fig. 5 A Prescribed Circular Trajectory

4.1 Prescribed trajectory

To validate the effectiveness of the proposed control schemes, a desired input end-effector trajectory is introduced. As a trajectory control procedure, it is required that the control action of the robot arm causes it to track or follow the desired path. A circular trajectory is generated considering the following time (t) dependent functions for the cartesian coordinate:

$$x_{bar1} = 0.25 + 0.1 * \sin (V_{cut}/0.1 * t) \quad (7)$$

$$x_{bar2} = 0.1 + 0.1 * \cos (V_{cut}/0.1 * t) \quad (8)$$

where the introduced end point tangential velocity, V_{cut} is assumed to be 0.2 m/s. Fig. 5 shows the graphical representation of the trajectory in the x-y coordinate.

4.2 Disturbances

A number of disturbances is considered in the simulation study to investigate the effectiveness and robustness of the system. The disturbances introduced in the simulation are:

- constant disturbance torque at the joints, $T_d = 10 \text{ Nm}$
- horizontal harmonic force at the end of link 2, $F = 15\sin 5t \text{ N}$
- spring (linear) force at the end of link 2 with spring stiffness, $k = 250 \text{ N/m}$

5.0 RESULTS AND DISCUSSIONS

Figures 6 through 13 show the plotted results obtained from the simulation. It is obvious that the trajectories generated by the AFC scheme are by far, superior than those obtained for the PD counterpart even in the presence of all the external disturbances under consideration. Therefore, the proposed AFC system exhibits a high degree of robustness and accuracy. The track errors for AFC are very small – implying that the arm end effector follows or tracks the trajectory very well giving very smooth output almost resembling the desired trajectories. The coordinate and trajectory control of the arm using this scheme is thus shown to be excellent. The minimum mean track error for AFC is computed to be about 0.298 mm when there is no disturbance while the maximum error is 0.886 mm obtained when the spring force is present. The difference in performance between the system with disturbances and the one without for AFC is thus very marginal. On the other hand, for PD control, the minimum error is 1.294 mm without disturbance and a maximum value of 8.386 mm is registered when the disturbance is in the form of constant torque at joint – indicating a significant range of error.

As predicted, when PD control method is used, the desired trajectory is well followed when there is no external disturbance acting on the system, while it is significantly distorted (shown in figures as dashed lines) when disturbance exists as shown in Fig. 7. This implies that the performance of PD control degrades with

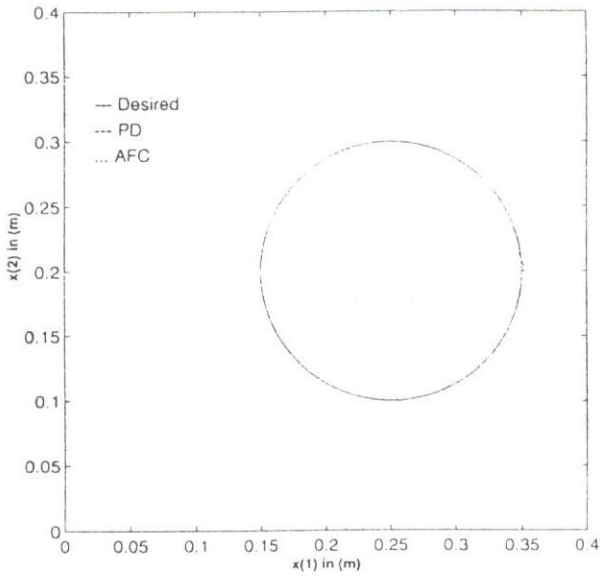

Fig. 6 Actual Trajectory of the End Effector, no Disturbance

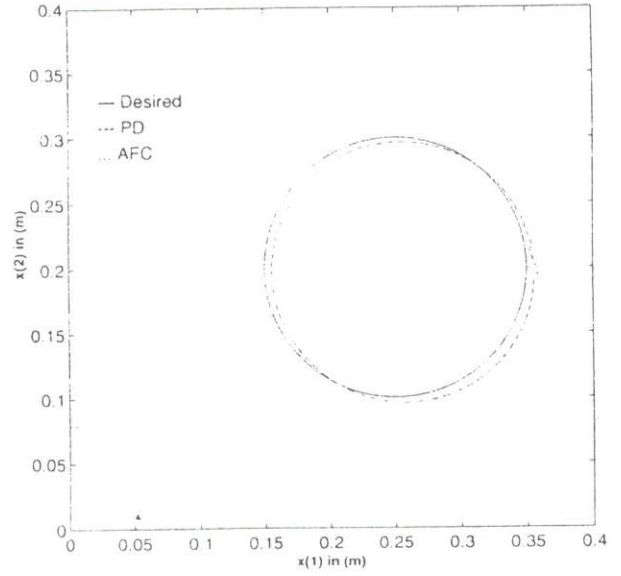

Fig. 7 Actual Trajectory of the End Effector, $T_d = 10$ Nm

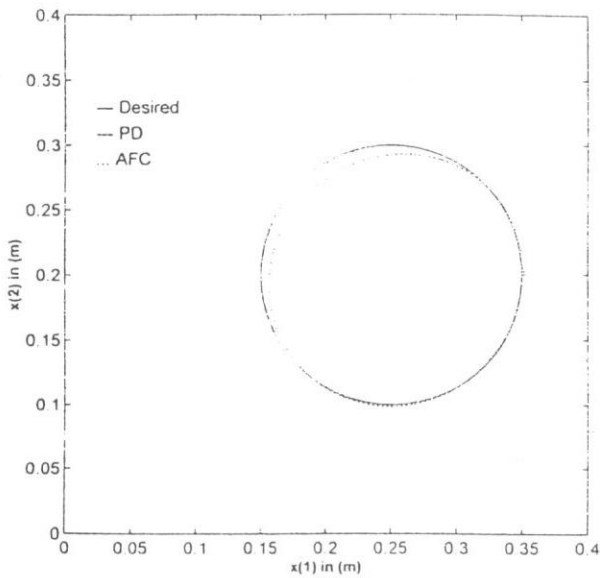

Fig. 8 Actual Trajectory of the End Effector, $k = 250$ N/m

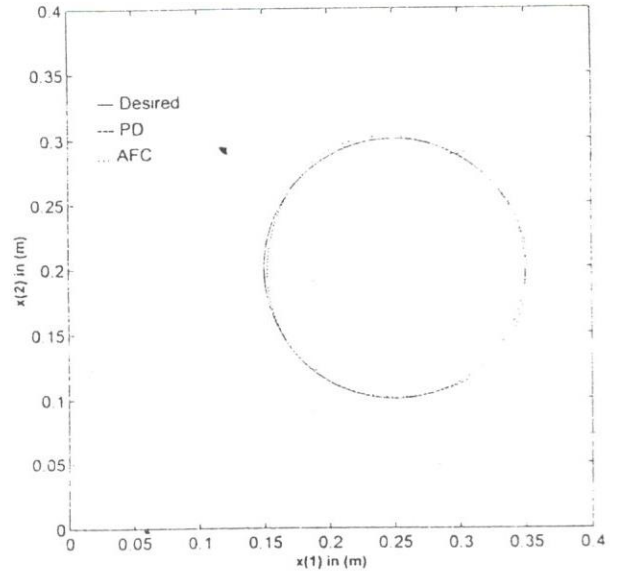

Fig. 9 Actual Trajectory of the End Effector, $F = 15\sin 5t$ N

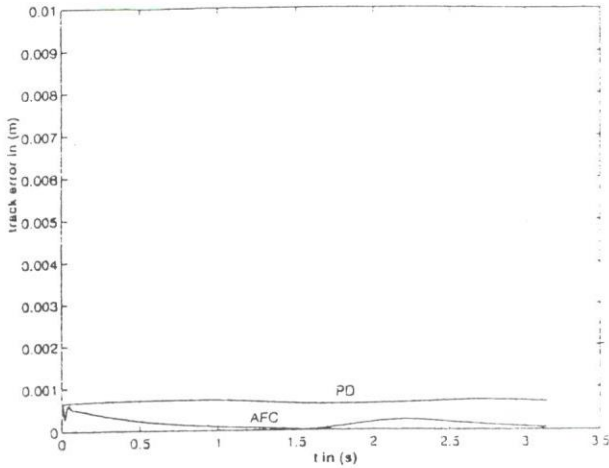

Fig. 10 Track Error
- No Disturbance

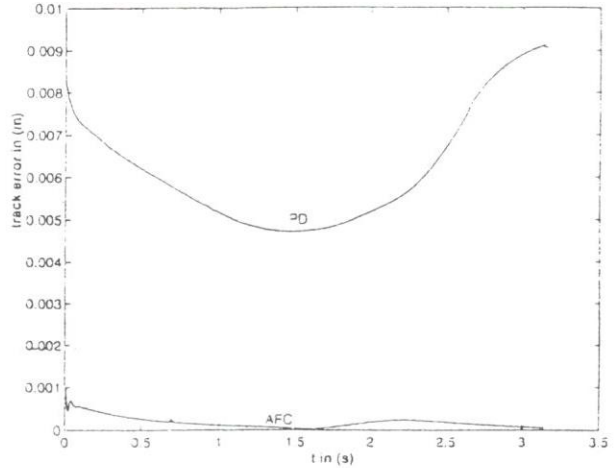

Fig. 11 Track Error
- With Disturbance, $T_d = 10 \text{ Nm}$

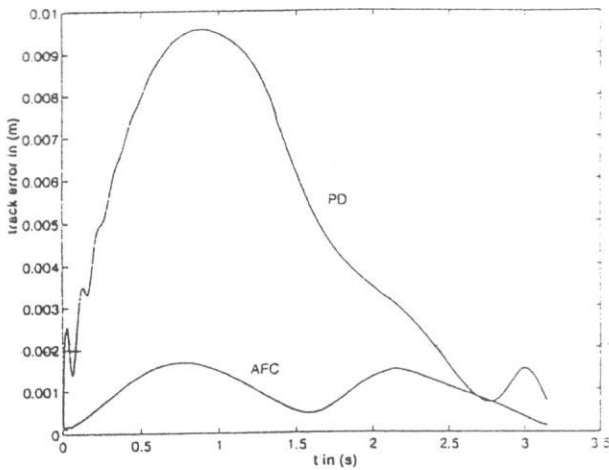

Fig. 12 Track Error
- With Disturbance, $k = 250 \text{ N/m}$

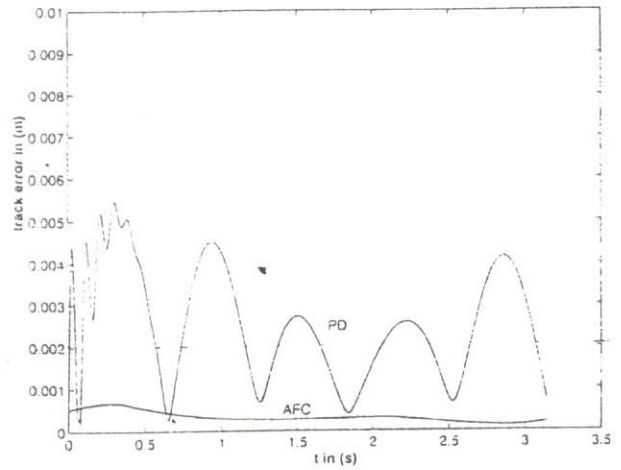

Fig. 13 Track Error
- With Disturbance, $F = 15\sin 5t \text{ N}$

disturbance in contrast to the AFC strategy which gives excellent 'all-round' performances. The distortion of the trajectory obtained corresponds to the nature of the disturbances acting on the robot arm. This is evident when the spring force is applied under PD control. The dashed lines in Figure 8 shows that the movement of

the end-effector of the robot arm tends to shift towards the direction of the spring origin (fixed point). The dotted lines representing the trajectory followed by the AFC scheme also indicates similar characteristic but almost undistinguishable from the desired trajectory.

In general, from the error curves in Figure 10 through 13, it can be seen that the track error for the constant disturbance torque is more uniform compared to the other two forces (spring and harmonic) which show significant fluctuations in the form of irregular sinusoidal curves. These fluctuations are due to the characteristic of the applied forces – the spring always maintains the tension/compression force at the end of the second link while the harmonic force constantly generates continuous cyclic force on the arm.

Table 1 Results of Analysis

Control Scheme	Mean track error (m)			
	No Disturbance	Td=10 Nm	k=250 N/m	F=15sin5t N
AFC	0.000298	0.000262	0.000886	0.00085
PD	0.001294	0.008386	0.003872	0.00574

6.0 CONCLUSION

It is clear that AFC method described in this study is extremely robust even in the presence of disturbances and uncertainties. The maximum mean tract error is found to be very small (less than 1 mm) when compared to the PD control method (more than 8 mm) when there is some disturbance. The PD control scheme produces satisfactory results only when there is no external disturbances acting on the system. The performance however, suffers considerably in the presence of disturbances.

A number of experimentation is suggested for further work. Different simulating conditions should be tried with different types of disturbances and payloads, prescribed trajectories and other parameter constants and by varying the estimated inertia matrix. Further investigation on the systematic approach to computing the estimated inertia matrix should also be carried out. There is an

enormous scope in incorporating intelligent mechanisms such as the use of neural network and fuzzy logics to estimate the inertia matrix exists. Already works in this area have been initiated by the authors and preliminary research shows promising results.

REFERENCES

1. Groover, M.P, Weiss, M., Nagel, R.N and Odrey, N.G., *Industrial Robotics: Technology, Programming and Applications*, McGraw-Hill Book Co. 1986.
2. Zheng, and Dawson, *Robust Tracking Control of Robot Manipulators*, Publishers, 1995.
3. Dubowsky, S., Desforges, D.T., *The Application of Model Referenced Adaptive Control to Robotic Manipulators*, Transactions of ASME, Journal of Dynamic Systems, Measurement and Control, Vol. 101, pp 193-200.
4. Slotine, J-J.E, Li, W, *Adaptive Manipulator Control: A Case Study*, IEEE Transactions on Automatic Control, Vol. 38, No. 11, pp 995-1003, 1988.
5. Leahy, M.B., Jr., Johnson M.A, Rogers, s.k., 1991, *Neural Network Payload Estimation for Adaptive Robot Control*, IEEE Transactions on Neural Network, Vol. 2, No. 1, pp 93-100.
6. Yao B., Tomizuka M, 1995, *Adaptive Control of Robot Manipulators in Constrained Motion – Controller Design*, Transactions of the ASME, Journal of Dynamic Systems, Measurement and Control, Vol. 117, September 1995, pp 321-8.
7. 7. Astrom K.J., McAvoy T.J., *Intelligent Control : An Overview and Evaluation*, David A. White, Donald A. Sofge, Eds., *Handbook of Intelligent Control : Neural, Fuzzy and Adaptive Approaches*, Van Nostrand Reinhold, New York, 1992, pp 3-34, 1992.
8. Uhl T., Szymkat, M., *A Comparison of the Classical and Neural Based Approach to Control of Manipulator*, Procs. of Conference on Experimental and Numerical Methods in Structural Dynamics, Leuven, Belgium, September 1992.

9. Cheng, W., and Wen, J., A Two-Time-Scale Neural Controller for The Tracking Control of Rigid Manipulators, IEEE Transactions of Systems, Man and Cybernetics, vol. 24, No. 7, pp 991-1000, 1994.
10. Shibata M., Murakami, T. and Ohnishi, K., A Unified Approach to Position and Force Control by Fuzzy Logic, IEEE Transactions on Industrial Electronics, Vol. 43, No. 1, pp 81-7, 1996.
11. M.H. Raibert, J.J. Craig, Hybrid Position/Force Control of Manipulators, Transaction of the ASME, Journal of Dynamic Systems, Measurement and Control, Vol. 102, June 1981, pp 126-133.
12. Hewit, J.R., Burdess, J.S., Fast Dynamic Decoupled Control for Robotics Using Active Force Control, Mechanism and Machine Theory, 1981.
13. Komada S. and Ohnishi K., Force Feedback Control of Robot Manipulator by the Acceleration Tracing Orientation Method, IEEE Transactions on Industrial Electronics, Vol. 37, No. 1, February 1990, pp 7-12, 1990.
14. Hewit J.R., Advances in Teleoperations, Lecture Notes on Control Aspects, CISM, 1988,
15. Hewit J.R. and Burdess J.S., An Active Method for the Control of Mechanical Systems in The Presence of Unmeasurable Forcing, Transactions on Mechanism and Machine Theory, Vol. 21, No. 3, pp 393-400, 1986.
16. Hewit J.R., Marouf K.B., Practical Control Enhancement via Mechatronics Design, IEEE Transactions on Industrial Electronics, Vol. 43, No. 1, pp 16-22, February 1996.
17. Asada, H. and Jean Slotine, J.J., Robot Analysis and Control, John Wiley and Sons Inc., 1986.
18. The Math Works Inc., The Student Edition of SIMULINK, Dynamic System Simulation Software for Technical Education, User's Guide, Prentice Hall Inc., 1996.