

OTEC PERFORMANCE EVALUATION USING DIFFERENT WORKING FLUIDS AND VARIATIONS IN OPERATING ORC CONDITIONS

Muhammad Ajwad Wahinuddin¹, Mohd Nazri Mohd Nasir^{1,2}, Nik Ahmad Ridhwan Nik Mohd^{1,2*}, Norazila Othman^{1,2}, Shabudin Mat^{1,2}, and Sathiabama T. Thirugana³

¹Faculty of Mechanical Engineering, Universiti Teknologi Malaysia, 81310, Johor Bahru, Johor, Malaysia

²UTM Aerolab, Institute for Vehicle System and Engineering (IVeSE), Universiti Teknologi Malaysia, 81310 Johor Bahru, Johor, Malaysia

³Razak Faculty of Technology and Informatics & UTM Ocean Thermal Energy Centre, Universiti Teknologi Malaysia, 54100, Kuala Lumpur, Malaysia

*Corresponding email: ridhwan@utm.my

Article history

Received
29th December 2022

Revised
30th May 2023

Accepted
30th May 2023

Published
25th June 2023

ABSTRACT

Ocean Thermal Energy Conversion (OTEC) is a system that produce energy of electricity by exploiting the temperature difference between surface part of seawater and deep region of seawater. The thermal energy at the surface seawater is used to convert working fluid into vapor which expands in the turbine to generate electricity and revert into liquid state by rejecting heat to cold seawater pumped from deep region of seawater. Basically, there are various types of working fluids that can be applied in an OTEC system depending on its contribution towards the performance of the system. In this study, the thermodynamics efficiency and net power output of basic OTEC system will be evaluated by varying three parameters which are the turbine inlet temperature, turbine inlet pressure and condenser outlet temperature using various working fluids through simulation using MATLAB. Simulation results indicate that R717 excels in producing the highest net power output but R600a has the best average value in thermodynamic efficiency. The findings of this work can contribute in giving an insight on which working fluid has the optimal characteristics in obtaining the best performance of the OTEC system.

Keywords: OTEC system, Organic Rankine Cycle, Working Fluid, Efficiency, Net Power Output

© 2023 Penerbit UTM Press. All rights reserved

1.0 INTRODUCTION

The Ocean Thermal Energy Conversion (OTEC) system utilises the Rankine cycle to manage the temperature difference between warm seawater at the surface (24–30 °C) and cold seawater in the deep region of the ocean (6–8 °C) in order to generate power [1][2]. As numerous OTEC plants have been built in various locations, such as Hawaii and Japan, they have significantly contributed to the generation of power as well as other by products, such as freshwater and food for mariculture [3]. The study of OTEC is still ongoing, though, as a result of the system's net efficiency being still only 2 to 5 percent due to the shallow temperature difference between the surface and deep regions of the ocean, which can range from 10 to 25 °C, depending on the region [4]. Since choosing the appropriate working

fluid is one of the key factors in ensuring the system's functionality, this is one strategy used by researchers to enhance the OTEC system's performance [5].

Choosing the best working fluid is essential because it is closely related to many different factors, including obtaining data on the system's optimal performance, obtaining a simple cycle structure, obtaining small component sizes, and ensuring the system operates safely [6]. The Organic Rankine Cycle (ORC) is considered to be the best technique for OTEC application to generate power, according to Wang et al. (2018). This is because, in contrast to the conventional Rankine cycle, which uses water as the medium for heat exchange, it uses organic working fluids, which have advantages in terms of thermophysical properties, cycle architecture, and determining component sizes. According to their Ozone Depletion Potential (ODP) and Global Warming Potential (GWP) values, organic working fluids have a worse environmental impact than water, which is a drawback. Despite this, a number of organic working fluids have low environmental impacts, as evidenced by low ODP and GWP values, which enables them to be reconsidered for use in OTEC systems.

Wet, dry, and isentropic fluids can all be categorised as organic working fluids, with wet fluids having a negative slope of the saturation vapour curve in the T-s diagram and dry and isentropic fluids having positive and vertical slopes, respectively [7]. These slopes frequently have an impact on the working fluid state at the turbine outlet of a cycle, where wet fluids usually appear as a mixture and dry and isentropic fluids have a significantly higher dryness fraction than wet fluids [8]. Working fluids have additionally demonstrated thermodynamic characteristics like boiling point, critical temperature, latent heat, specific heat capacity, and thermal conductivity, which are said to be directly related to cycle performance [9]. The following highlights the significance of these characteristics: in order to allow for state conversion in the evaporator, a working fluid's boiling point must be lower than the heat source. Concerning critical temperature, they claimed that since a working fluid with a higher critical temperature can reach a higher evaporation temperature, it gives a much higher system efficiency. Due to the fact that low latent heat allows almost all of the heat to be added during phase change, low latent heat when using low grade heat source favours higher system efficiency and net power output. Additionally, in order to achieve a high coefficient of heat transfer, a high thermal conductivity is also necessary. On the other hand, a working fluid's specific heat capacity needed to be low in order to lessen pump work and increase work output [10].

Since both criteria complement one another, relying solely on working fluid without taking operation parameters into account would not significantly affect system performance. The turbine inlet and condenser outlet are the critical points in a typical Rankine cycle, where the parameters of temperature and pressure have been shown to have a significant impact on cycle performance [11]. OTEC system efficiency is relatively low due to the low temperature difference in seawater, so researchers have tried a variety of methods to raise the turbine inlet parameters, including integrating solar collectors and using geothermal energy as the heat source. Similar circumstances exist at the condenser outlet, where changing the temperature there may have an impact on how well the system works. Different working fluids operated at various temperatures and pressures; therefore, it is critical to determine which working fluids, when combined with the turbine inlet and condenser outlet parameters, produce the desired results.

In this study, various working fluids will be used and analysed to find the best working fluid that could improve an OTEC system's performance. In order to assess the performance of the OTEC system in terms of its thermodynamic efficiency and net power output, the turbine inlet and condenser outlet parameters turbine inlet temperature, turbine inlet pressure, and condenser outlet temperature will be taken into account. This study's goal is to improve simulation models of basic OTEC systems by identifying the best working fluids through thermodynamic analysis of each working fluid's impact on system performance.

2.0 METHODOLOGY

2.1 System Description

The basic organic Rankine cycle-based OTEC system is depicted schematically in Figure 1 along with its state points of analysis, which are depicted on the T-s diagram in Figure 2. Turbine, evaporator, condenser, and pump make up the OTEC system's four main parts. To find the best one that could provide the system's maximum performance in terms of thermodynamic efficiency and net power output, a variety of working fluids from the three phases of dry, wet, and isentropic fluids are used. The temperature of the seawater flowing into the evaporator and condenser is based on the typical ocean temperatures in the tropical region, which are 6-8 °C for the deep region of the ocean and 24-30 °C for the surface part of the ocean.

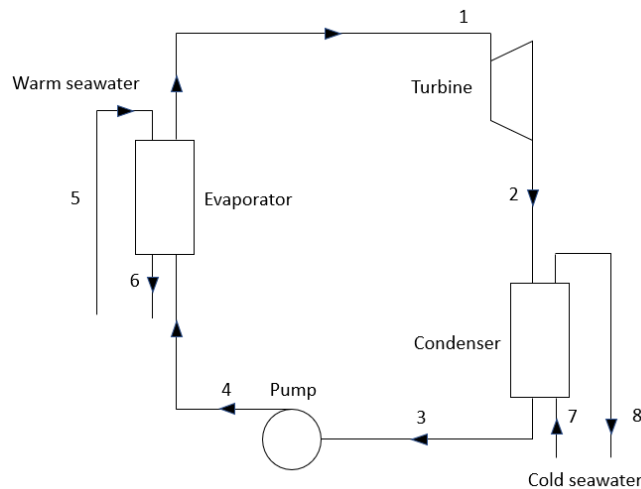

Figure 1: Schematic diagram of a basic OTEC cycle

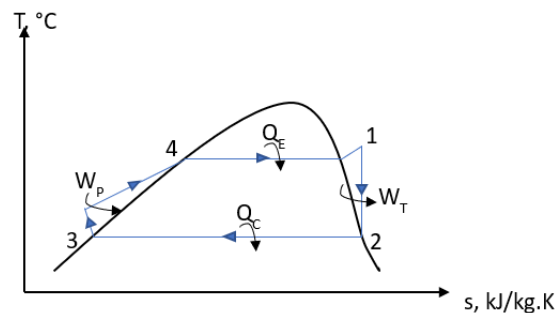

Figure 2: T-s diagram

Referring to Figures 1 and 2, the following thermodynamic processes comprise the OTEC system. In the evaporator, the working fluid changes from liquid to vapour due to heat exchange with warm seawater. This process is depicted in the T-s diagram from state 4 to state 1 where the pressure is constant. The vapour will then expand in the turbine to produce electricity, representing a transition from state 1 to state 2. In this state, the process is known as isentropic expansion because no heat transfer occurred. After leaving the turbine, the vapour will return to liquid form by rejecting heat to the cold seawater in the condenser, as depicted by the transition from state 2 to state 3. This process, like the evaporator, maintains constant pressure, but at a much lower value. The cycle is then completed by pumping the working fluid back to the evaporator.

In an OTEC system that employs ORC, it is required to choose the optimal working fluid in order to achieve maximum performance and ensure long-term safety. The working fluids shown in Table 1 were selected based on their Ozone Depletion Potential (ODP) and Global Warming Potential (GWP) values, which measure their environmental impact. The performance of the OTEC system will be assessed based on the thermophysical properties of the selected working fluids, specifically the specific heat capacity, thermal conductivity, and latent heat. Figures 3 and 4 depict the slope of the saturation vapour curve and the thermophysical properties of each fluid, respectively.

Table 1: Thermodynamics data for working fluids

Working fluid	Group	Boiling point (°C)	Critical temperature (°C)	Ozone Depletion Potential (ODP)	Global Warming Potential (GWP)
R123	Dry	27.6	183.68	0.06	77
R600a	Dry	-11.7	134.98	0	3
R290	Wet	-42	96.7	0	3
R717	Wet	-33.4	132	0	0
R1234yf	Isentropic	-30	94.7	0	4
R1234ze	Isentropic	-18.95	109.37	0	6

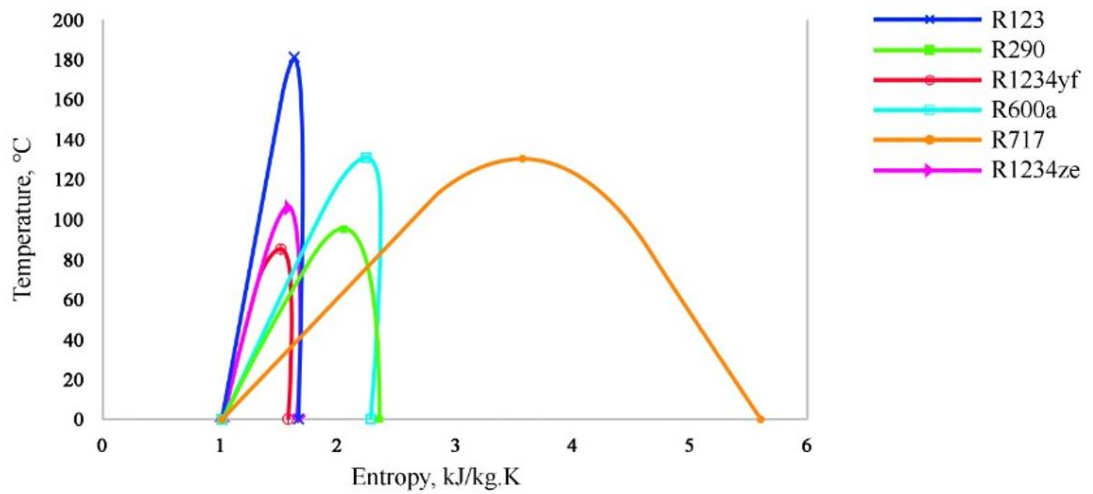
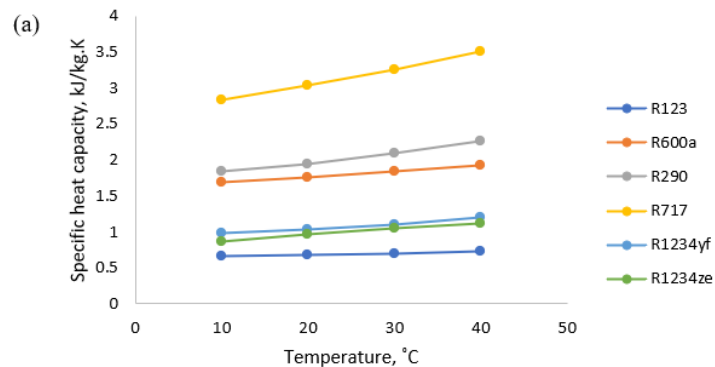

Figure 3: Saturation vapor curve for the selected working fluids



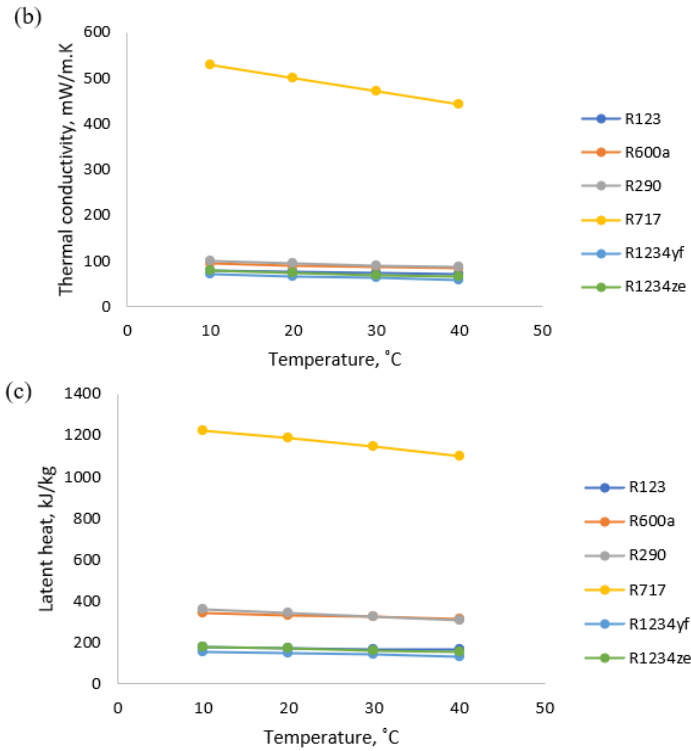

Figure 4: Temperature-dependant of thermophysical properties for each working fluid (a) Specific heat capacity, (b) Thermal conductivity, (c) Latent heat

The mathematical model of the OTEC system (referred to Figure 3) is computed as follows:

$$\eta = \frac{W_{net}}{Q_E} = \frac{(h_1 - h_2) - (h_4 - h_3)}{h_1 - h_4} \quad (1)$$

Evaporator:

$$Q_E = M_f(h_1 - h_4) = M_w c_p(T_5 - T_6) \quad (2)$$

Turbine:

$$W_T = M_f(h_1 - h_2) \quad (3)$$

Condenser:

$$M_f = (h_2 - h_3) = M_c C_L(T_8 - T_7) \quad (4)$$

Pump:

$$W_P = M_f(h_4 - h_3) \quad (5)$$

The operating conditions and presumptions that will be used to analyse the OTEC system's performance are shown in Table 2. The following three variables, which have an impact on the thermodynamic efficiency and net power output, were examined using the calculation results from the analysis conditions in Table 1:

Table 2: Assumptions and operating condition for OTEC cycle

Parameter	Value	References
Turbine isentropic efficiency (%)	80	(Javanshir et al., 2017)
Pump isentropic efficiency (%)	85	(Javanshir et al., 2017)
Working fluid mass flowrate (kg/s)	0.1	(Faizal & Ahmad, 2013)
Turbine inlet temperature (°C)	22-40	(Hung et al., 2010)
Condenser outlet temperature (°C)	5-10	(Hung et al., 2010)

2.2 MATLAB Flowchart for Parametric Analysis

Figure 5 shown is the process flow of the OTEC cycle scripted by using MATLAB. Pay attention to the process shown where it is demonstrated by manipulating turbine inlet temperature only. The purpose of this is only to visualize how the programming was done in the software.

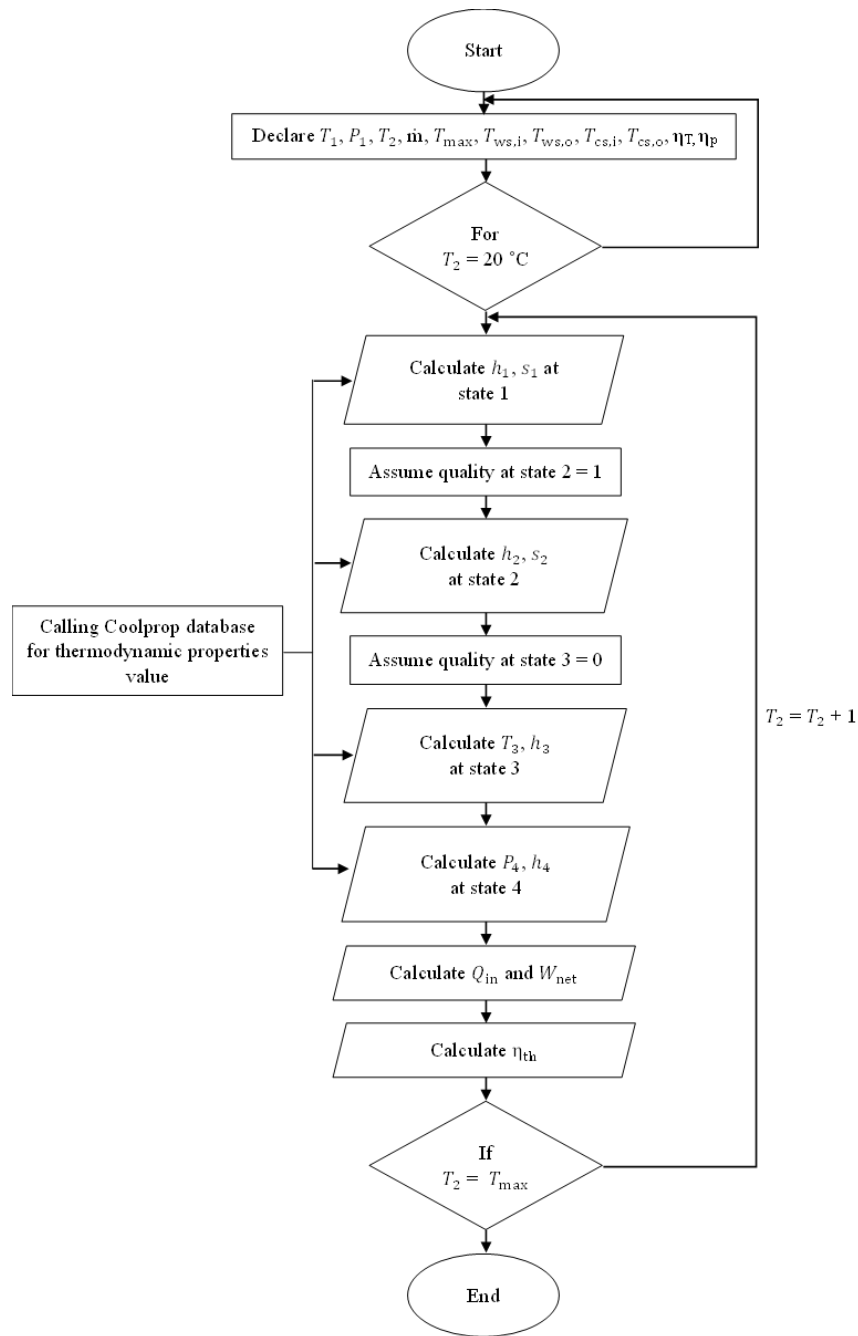

Figure 5: MATLAB process flow

The process begins by connecting the MATLAB programming with CoolProp to acquire the properties of the working liquid that is chosen in the initial phase of the simulation. Then, at that point, a couple of known variables are instated ahead of time as per the assumptions that has been made in Table 2. The computation begins by identifying the enthalpy and entropy of the fluid at the evaporator outlet, which is signified as state 1, by utilizing the assumed temperature and tension by then.

The process then continues to the state 2, which is the turbine outlet. Here, the entropy value is equivalent to the value in state 1, while the enthalpy is determined by utilizing the temperature and quality value of the working liquid. The quality value is denoted as 1 since one of the constraints is to ensure that the condition of the working liquid at the turbine outlet is in saturated vapor state.

Continuing on toward the following point which is state 3, the temperature at this location is designated to the assumed temperature, while the enthalpy is determined utilizing the temperature and quality value. As seen in the coding, the quality is assumed to be 0 to picture a saturated liquid state at the condenser outlet. In addition, the pressure and specific volume are also determined, as the two variables will be utilized in the following computation.

In state 4, which represents the evaporator inlet, the pressure is assumed to be similar to in state 1, as to show that there is no pressure drop across the evaporator. Additionally, the pump work is determined by utilizing the specific volume and pressure difference between state 3 and state 4, alongside the assumed work of pump. Then, the enthalpy at this point is determined by using the enthalpy value at state 3 and work of pump.

```
% Thermodynamic properties at point 1
H_1 = py.CoolProp.CoolProp.PropsSI('H', 'T', T_1, 'P', P_1, 'R717');
S_1 = py.CoolProp.CoolProp.PropsSI('S', 'T', T_1, 'P', P_1, 'R717');

% Thermodynamic Properties at Point 2
S_2 = S_1;
H_2 = py.CoolProp.CoolProp.PropsSI('H', 'T', T_2, 'Q', 1, 'R717');

% Thermodynamic Properties at Point 3
T_3 = T_2;
P_3 = py.CoolProp.CoolProp.PropsSI('P', 'T', T_3, 'Q', 0, 'R717');
D_3 = py.CoolProp.CoolProp.PropsSI('D', 'T', T_3, 'Q', 0, 'R717');
SV_3 = 1/D_3;
H_3 = py.CoolProp.CoolProp.PropsSI('H', 'T', T_3, 'Q', 0, 'R717');

% Thermodynamic Properties at Point 4
P_4 = P_1 ;
PW = (SV_3 * (P_4 - P_3))/Pump_eff ;
H_4 = H_3 + PW ;
```

Figure 6: State 1 – 4 for specific enthalpy and entropy

Finally, the result of the analysis which are the heat input, work of turbine, net power output and cycle efficiency are determined as displayed in Figure 7. When the calculation is finished, the process will circle back to the initial process with the increase of the turbine inlet temperature and stops in the event that it arrives at its upper limit as expressed in Table 2. This cycle is repeated with other working fluids until the goals are accomplished. In addition, the cycle stream in MATLAB for the other two manipulated variables, which are the turbine inlet pressure and condenser outlet temperature are using the same concept as above, by just changing the selected variables while keeping the other as constant.

```
%Performance
HI = M_ORC * (H_1 - H_4) ;
TW = (M_ORC * (H_1 - H_2))*Turb_eff;
SOP = TW - PW ;
Cycle_eff = SOP/HI;

T_2 = T_2 + 1;|
end
```

Figure 7: Performance parameter calculation

3.0 RESULTS AND DISCUSSION

3.1 Effect of turbine inlet temperature on thermodynamic efficiency and net power output

Figure 8 shows the variation in thermodynamic efficiency and net power output with different turbine inlet temperature values for six different working fluids. The trend in thermodynamic efficiency rises as the turbine inlet temperature rises. At a temperature of 40 °C, R600a and R717 show the highest and lowest efficiency, with 5.1 percent and 4.5 percent, respectively. The enthalpy of each working fluid at the turbine inlet provides evidence of the cause of this result. In comparison to other working fluids, R717 has a higher enthalpy value as saturated vapour, as shown in the property table. Due to the predetermined fact that the evaporator inlet temperature will remain constant throughout all parameter analyses, R717 exhibits a significant enthalpy difference when compared to other working fluids. Since they are inversely proportional to one another, as shown in Equation (1), the thermodynamic efficiency of the system decreases as the enthalpy difference between the evaporator inlet and outlet increases. The efficiency of the system can change depending on the thermophysical characteristics of the working fluids. High heat input is required for phase change to occur in R717 due to its high latent heat. Because of the low temperature and low heat energy of the warm seawater as a heat source, efficiency is decreased. When compared to R717, which only needs a small amount of heat input to transition from a liquid to a vapour phase, R600a has low latent heat.

The graph for thermodynamic efficiency, which is in increasing order as the temperature at the turbine inlet increases, has the same pattern for the power produced by the OTEC system. At this temperature of 40 °C, R717 has the highest net power output of 5.6 kW, which is five times greater than that of other fluids, which only produce 1 to 2 kW at the same temperature. A higher temperature results in a higher enthalpy value at the turbine inlet, which causes the turbine to perform more work overall, explaining the difference in power output between low and high temperatures. Additionally, R717 has an advantage in producing more power because it has a much higher enthalpy value than other working fluids.

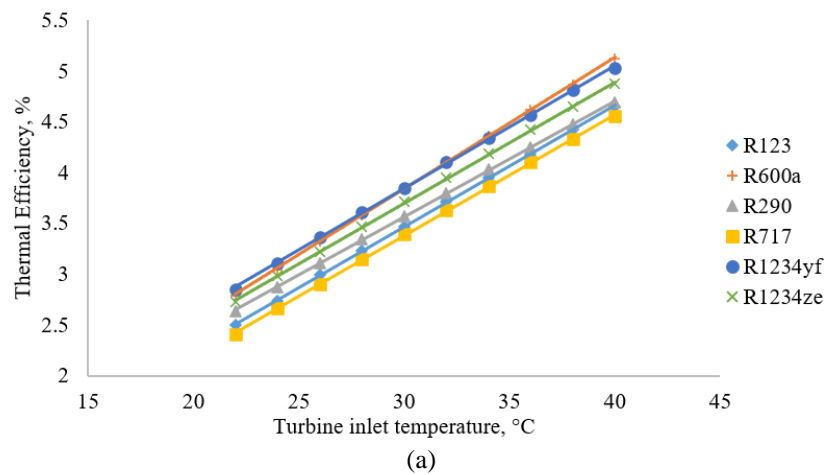

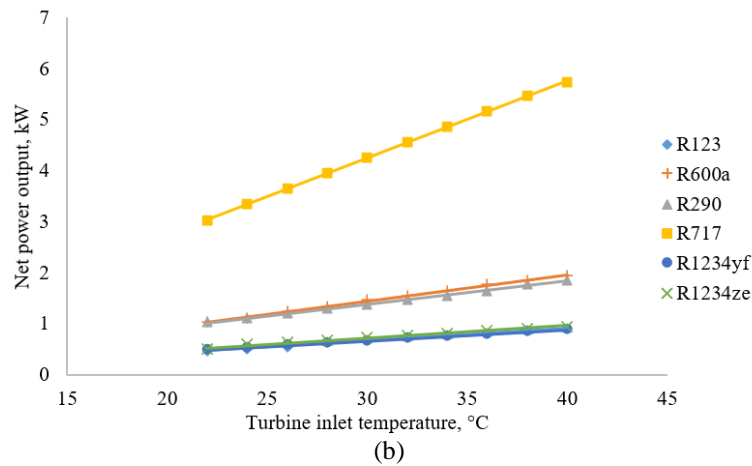

Figure 8: Turbine inlet temperature versus (a) thermodynamic efficiency and (b) net power output

3.2 Effect of turbine inlet pressure on thermodynamic efficiency and net power output

The net power output and thermodynamic efficiency for each working fluid at each pressure were shown in Figure 9. From the standpoint of thermodynamic efficiency, R123 completely dominates the outcome, providing the highest value of 5.2 percent at a fixed turbine inlet temperature of 22 °C and 550 kW. R717 exhibits the lowest thermodynamic efficiency, with only 3.5 percent at 1100kW of pressure. Working fluid R717 managed to reach the highest value in terms of net power output, which is roughly 4.2 kW, at a turbine inlet pressure of roughly 1000 kPa. In comparison to R717, other working fluids appear to have very low peak power outputs of between 1 and 2 kPa. As a result, R717 is now being considered as a working fluid that can be used in the OTEC system. Additionally, as shown in Figure 9, R717 has a much wider operating working pressure than R123, which drops significantly when the pressure is slightly increased. As a result, R717 is now more adaptable and can be used with significant pressure changes without worrying about a sudden drop in performance. To operate this working fluid, though, very high pressure is necessary. A higher operating pressure necessitates the use of high-performance equipment, which raises the cost.

The thermodynamic efficiency and net power output of each working fluid, however, start to decline after they reach their peak points, as shown in Figure 9. The reason for this pattern is that each working fluid has its saturation pressure at a fixed temperature of 22 °C, which is taken as the inlet temperature for the turbine. The working fluid at the turbine inlet will turn liquid when the saturation pressure is exceeded, harming the turbine blade. In order to prevent further system damage, it is best not to recklessly increase the pressure at the turbine inlet.

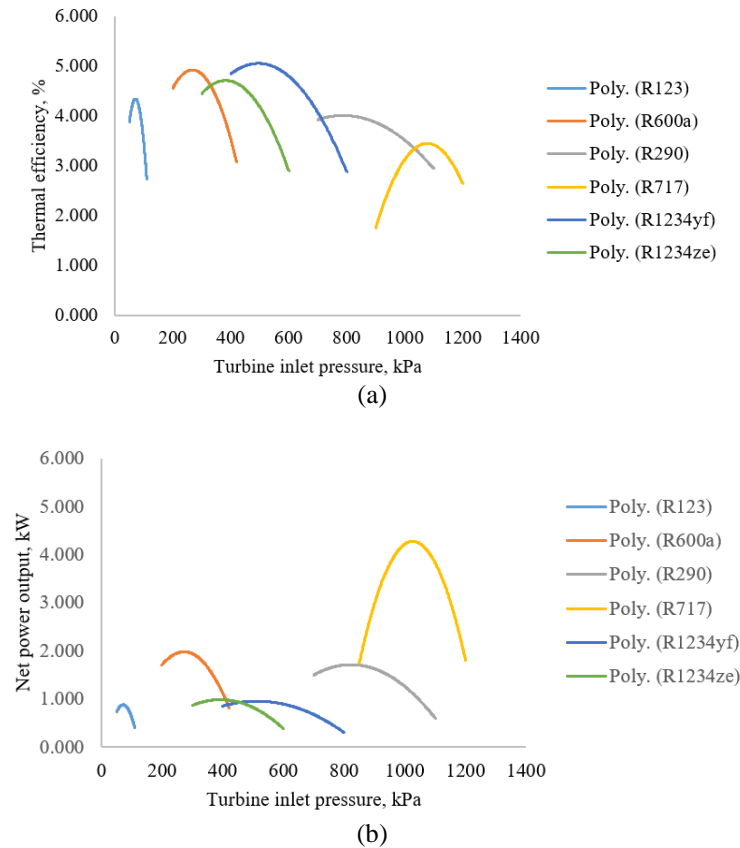

Figure 9: Turbine inlet pressure versus (a) thermodynamic efficiency and (b) net power output

3.3 Effect of condenser outlet temperature on thermodynamic efficiency and net power output

Figure 10 presented the results of thermodynamic efficiency and net power output when varying condenser outlet temperature. From the figures, the graphs pattern differs from the two parameter studies as the graphs are in decreasing manner as the temperature at condenser outlet increases. The reasonable explanation for this output can be observed on the work required by the pump to elevate the temperature at its inlet to achieve the temperature at the outlet which has been declared as constant for this parameter analysis. For instance, as the condenser outlet temperature rises, the pump can achieve the constant temperature declared at the beginning of the analysis with less effort because the temperature difference between the pump inlet and outlet is small. Consequently, according to the equation for net power output and thermodynamic efficiency shown in Equation (1), a higher condenser outlet temperature results in a lower net power output, as well as a decrease in the system's thermodynamic efficiency, as their relationship is directly proportional.

With a thermodynamic efficiency of 4.5% at a condenser output temperature of 5 °C, R600a has the greatest value when compared to other working fluids. But R717 manages to have the best efficiency with a value of 3% at higher condenser outlet temperature, which in this study is 10 °C. This includes the net power output, where R717 exhibits a substantial variation from other working fluids. The greatest value would be 5.1kW at the condenser outlet temperature of 5 °C and would drop to 3.3kW at a temperature of 10 °C.

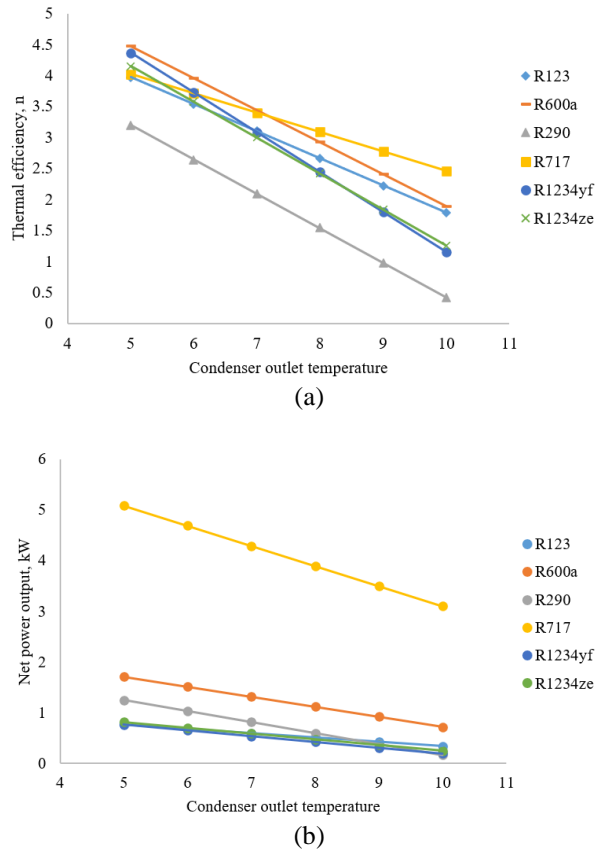

Figure 10: Condenser outlet temperature versus (a) thermodynamic efficiency and (b) net power output

4.0 CONCLUSION

The performance of an OTEC system was tested using several working fluid types in the current work. R123, R290, R600a, R717, R1234yf, and R1234ze are the six working fluids that are employed. The results suggest that R600a performed best in terms of thermodynamic efficiency, whereas R717 dominated the amount of power produced by the turbine. The greatest results are produced when system parameters and the thermophysical characteristics of the working fluids are combined. Since R717's thermodynamic efficiency and R600a's efficiency are so closely matched, R717 appears more likely to be chosen as the best working fluid. The only factor in this investigation is the requirement for high performance equipment when using R717 as the working fluid because it must be operated under high pressure. In addition, it can be shown that each working fluid's net power production and thermodynamic efficiency started to decline at a certain pressure value after reaching their maximum levels. The working fluid is kept at the turbine inlet as a saturated liquid as a result of the pressure value being higher than the saturation pressure for the determined temperature. To prevent liquid from forming in the turbine, the pressure increment should be made with caution. In order to achieve the greatest outcomes for OTEC performance in the future, parameter optimization employing the optimal working fluid should be carried out.

ACKNOWLEDGMENTS

This work was funded by the Malaysian Ministry of Higher Education (MoHE) Long Term Research Grant Scheme (Vot number: R.J130000.7851.4L892), SATREPC-OTEC and IOES Saga University, Japan.

REFERENCES

1. Kim, N. J., Ng, K. C., & Chun, W. (2009), "Using the condenser effluent from a nuclear power plant for Ocean Thermal Energy Conversion (OTEC)," *International Communications in Heat and Mass Transfer*, Vol. 36, No. 10, 2009, pp. 1008–1013.
2. T Faizal, M., & Ahmed, M. R., "Experimental studies on a closed cycle demonstration OTEC plant working on small temperature difference," *Renewable Energy*, Vol. 51, 2013, pp. 234–240.
3. Buigues, G., Zamora, I., Mazón, A. J., Valverde, V., & Pérez, F. J., "Sea energy conversion: Problems and possibilities," *Renewable Energy and Power Quality Journal*, Vol. 1, No. 4, 2006, pp. 85–92.
4. Mohd Idrus, N. H., Musa, M. N., Yahya, W. J., & Ithnin, A. M., "Geo-Ocean Thermal Energy Conversion (GeOTEC) power cycle/plant," *Renewable Energy*, Vol. 111, 2017, pp. 372–380.
5. Yang, M. H., & Yeh, R. H., "Analysis of optimization in an OTEC plant using organic Rankine cycle," *Renewable Energy*, Vol. 68, 2014, pp. 25–34.
6. Babatunde, A. F., & Sunday, O. O., "A Review of Working Fluids for Organic Rankine Cycle (ORC) Applications," *IOP Conference Series: Materials Science and Engineering*, No. 413, 2018.
7. Wang, M., Jing, R., Zhang, H., Meng, C., Li, N., & Zhao, Y., "An innovative Organic Rankine Cycle (ORC) based Ocean Thermal Energy Conversion (OTEC) system with performance simulation and multi-objective optimization," *Applied Thermal Engineering*, Vol. 145, 2018, pp. 743–754.
8. Desai, N. B., & Bandyopadhyay, S., "Process integration of organic Rankine cycle," *Energy*, Vol. 34, No. 10, 2009, pp. 1674–1686.
9. Mago, P. J., Chamra, L. M., & Somayaji, C., "Performance analysis of different working fluids for use in organic Rankine cycle," *Proceedings of the Institution of Mechanical Engineers, Part A: Journal of Power and Energy*, Vol. 221, No.3, 2007, pp. 255–264.
10. Zhai, H., An, Q., & Shi, L., "Analysis of the quantitative correlation between the heat source temperature and the critical temperature of the optimal pure working fluid for subcritical organic Rankine cycles," *Applied Thermal Engineering*, Vol. 99, 2016, pp. 383–391.
11. Bao, J., & Zhao, L., "A review of working fluid and expander selections for organic Rankine cycle," *Renewable and Sustainable Energy Reviews*, Vol. 24, 2013, pp. 325–342.
12. h Dai, Y., Wang, J., & Gao, L., "Parametric optimization and comparative study of organic Rankine cycle (ORC) for low grade waste heat recovery," *Energy Conversion and Management*, Vol. 50, No. 3, 2009, pp. 576–582.