

HEAT-BASED AUTOMATED ON-THE-ROAD PAINTING MACHINE

Mas Omar Mas Rosemal Hakim and Musa Mailah

Faculty of Mechanical Engineering,
Universiti Teknologi Malaysia,
83100 UTM Johor Bahru,
Johor, Malaysia
musa@fkm.utm.my

ABSTRACT

This paper focuses on the design and development of a semi-automated road painting machine. The system design incorporates an electric bicycle as the prime mover to be driven by a human operator, which hauls a mobile platform that carries an automated and heat assisted paint delivery mechanism, capable of producing different straight line (single or double) patterns on the road. An Arduino-based microcontroller was used to execute data communication between the system devices through a written programming code for the operation of a desired painting task. A safety lamp and a camera with a reasonably large LCD screen were installed onto the system as additional commercially attractive features. A working prototype of semi automated road lane painting machine that intergrates mechanical, electric/electronic and computer control parts was tested in actual road conditions. The test indicated that 30% of the diluted paint mixture produces the best performance.

Keywords: *Design process, semi-automated, Arduino microcontroller, paint system, electric bicycle*

1.0 INTRODUCTION

In modern days, means of transport on land had evolved from walking, riding animals, riding bicycles to petrol-powered vehicles such as motorcycles, cars, buses, and trucks. To improve travelling time from one location to another, pavement road was introduced. One of the well-known modern road construction techniques was first developed by John McAdam, a Scottish engineer, in the early 19th century [1] involving the layering of roadbeds consisting of soil and cluster of crushed stones that were compacted by means of an impacting machine or a heavy roller. This fundamental technique was improved in the 20th century by the addition of tar as binder to produce concrete pavements referred to as bitumen or asphalt roads. The ease of mobility on asphalt roads had continued to enhance the economic development and standard living of a country. A major drawback of the increase in speed of travelling on land is the increase in accident not only between vehicles and but also between vehicles and pedestrians. Some of the collisions may result in grave consequences. As such, one of the ways to minimize accident and maintain efficiency of the flow of traffic is by having appropriate markings or lanes on concrete pavements. Generally, the marking are paint based material on pavement roads. The process of conventional road painting can be divided into two main tasks. The first is to determine the exact position of a line at the early stage by performing a pre-sketch marking onto the road surface. The second is to spray or discharge the paint onto the pre-sketch mark [2].

In Malaysia, the road lines are still currently been drawn using a typical manual operated road painting machine. The nature of the operation needs one human operator to push or handle the machine moving direction while at the same time, performing the painting task.

*Corresponding author: musa@fkm.utm.my

The painting operation is not only labour-intensive but quite slow that can leads to potential hazard such as being exposed to hot-melted paint and collision with the passing traffic [3].

Another problem of manual road lane painting operation is that it demands skill and experienced workers [4].

Hence, one of the promising methods to improve or overcome the issues is by introducing a semi-automated road lane painting concept that could potentially enhance productivity of the road lane painting operation in Malaysia.

The information regarding the existing road lane painting machine can be obtained by observation of active product being used on the road and the existing machine type being sold via internet by local vendors in Malaysia such as Teakway Industrial Sdn Bhd and R.S. Machineries Sdn Bhd [5-7]. The specifications for road lane markings are usually defined in catalogues and standard regulation documents [8–11]. The overall information related to the road lines specification size, line colour and allowable marking materials are obtained with reference to the Malaysian Public Work Department (*Jabatan Kerja Raya* (JKR)) manual in [12] in-line with the Malaysian road standards.

Search on previous works done by scholars and researchers was conducted on published patent for road painting applications. The patent search enables new knowledge and ideas to be obtained in the process of developing the proposed semi-automated road painting system. The patent search however is focused on machines patent aside from spraying mechanism to limit the scope of the design system and to lessen the use of pressurized spraying equipment that requires further expense and space set up in the system development. By reviewing published design drawings and text of patents, research done by others are greatly appreciated and detail possibilities of closing the gap or persisting problem arise for newly proposed system was addressed and resolved. The patents referred to are: Patent No. US3059574 [13], Patent No. US1738738 [14], Patent No. US2751618 [15], Patent No. US4269328 [16], Patent No. US2528657 [17].

A robotic system for road lane painting was developed by Woo *et al.* [3] for a semi-automated road painting system. The developed system is capable of performing re-painting of existing faded line using paint spraying nozzle on-site via vision tracking of the road line, so that the time consuming and hazardous operation can be eliminated. A crude prototype of a semi-automated road painting machine has been designed and developed by Jali [18] to perform the basic painting of a single straight continuous line. The system design utilizes an electric bicycle as its prime mover and a paint spraying system. The system is quite similar to the proposed system in this study in the selection of the prime mover.

It is the aim of the research to design and develop a semi-automated road painting system considered as an improved system in comparison to the works done in [2] and [18]. The proposed system consists of a heat-based painting device mechanism mounted on a mobile platform controlled by an operator who also controls the prime mover that propels the whole system based on electrically operated bicycle. The electric bicycle is an attractive choice as it is easy and safe to operate without any restriction on the road such as the need for riding license, low cost and readily available from the market. Furthermore, the fact that the road painting task does not require high speed operation makes it even more an excellent option.

2.0 PAINTED ROAD MARKS

The painted road mark that is being focused in this study is the road lines pattern that is used to represent the middle part of the road (centre line) that separate traffic travelling from both directions. The specification of the line width, line stroke length and the interval gap length between two line strokes differs according to the road areas which are either rural or urban. In rural areas, the line width is 100 mm, line spacing is 125 mm and interval gap is 7.5 m with 4.5 m stroke. However, on mountainous terrain or with short radius curves, a 4.5 m interval gap with 2.7 m stroke line is used. In urban areas, the line width is 100 mm, line spacing is 125 mm and interval gap is 1.7 m with 1 m stroke. Figure 1 shows the meaning of width, spacing, gap and stroke for centre line.

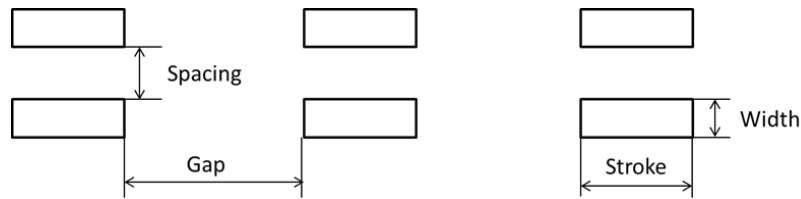

Figure 1: Width, spacing, gap and stroke for centre line

Other types of straight lines that are parallel to the road than the centre line are line inside the lane (lane line), line at the outer road side (edge line), and continuous line that is used to indicate the edge of that portion of a carriageway which is assigned to through traffic, and where it is intended that the line be crossed by traffic turning at the intersection, or entering or leaving an auxiliary lane at its starts or finish. All of these line are categorizes as longitudinal line on the road. Lines that are distinct from the longitudinal line can be classified as either transverse lines or other lines/markings. Transverse lines are perpendicular lines that are against longitudinal lines such as lines to mark intersection, junction controls, and traffic signals. Other lines/markings are those markings that differs from longitudinal and transverse lines such as lines and markings for yellow boxes, kerb marking, chevron, message on the road, arrows, railway cross mark, parking space line, pave shoulder marking, approaches to roundabout line and cross walks [12].

The line colour is generally restricted to white colour paint or marking. Yellow colour paint is an exception for drawing yellow boxes in urban areas, kerb markings showing parking prohibitions covered by signs or ordinance, parking bays for taxis, buses, and pedestrian crossing and yellow bars at approaches to roundabouts and crosswalks. The standard colour for yellow markings should follow the code 356 BS381C [12]. For this study, white colour paint will be used for testing as it conforms to all lines type in Malaysia. Commonly, there are three standard materials eligible to be used to mark the road surface which are liquid paint, thermoplastic paint and preformed tape. Liquid paint is the most versatile paint that is used for many painting application compared to thermoplastic paint which operates on one unit type of machine (road lane painting machine) described by Ali *et al.* [2]. It has low drying speed, short lifetime and is low cost. This paint is best used for road marking not subjected to heavy traffic wear on the road. Liquid road line paints conforming to MS164:1973, tested and approved by SIRIM are the one being used for road painting operation [12]. Thermoplastics paint that is acceptable to be used for road marking shall be of the hot-applied thermoplastic material conforming to BS3262 or the equivalent [12]. It is accepted as the most preferred material to mark lines on the road due to its good durability, high reflectivity and high skid resistance. The material is in solid powder form at 25°C. A pre-heater is essential to heat the solid powder into a viscous liquid form before spreading it on the road. Noted, that the thermoplastic paint needs to be handled in a cautiously manner to prevent skin burn accident. Next, a preformed tape is a type of plastic sheet that stick on to the road surface by means of adhesive. Satisfactory resistance to skidding is the determining factor to appropriately pattern or embossed the preformed tape markings. Note also that preformed tape markings are used as temporarily markings due to easy removability even after a prolonged time.

3.0 DESIGN PROCESS

The design and development of the proposed semi-automated on-the-road painting machine follows a complete engineering design process [19] that based on a full mechatronic system approach. As the system is semi-automatic, the automatic part of the system operation is clearly related to the usage of specific microcomputer-based or digital controllers. The control implementation may be done through a *Personal Computer* (PC), *Programmable Logic Controller* (PLC) and *Peripheral Interface Controller* (PIC) or microcontroller [20]. These digital controllers are used to execute all the data communication between the *Input and Output* (I/O) signals involving sensors, switches, actuators, and other devices through written programming code that is related to various commands involving the painting task. Appropriate power supply for all the I/O devices is important to ensure connectivity of the system via electrical/electronic circuitry to ensure the system workability. In any electrical/electronic project, the cost of the microcontroller is unavoidable. Therefore, in choosing a

microcontroller, low cost is deemed desirable without sacrificing the designed electrical and electronic requirement for input and output port that can be handled by the controller. The obvious lowest end microcomputer-based controllers to choose from are the PIC type, i.e., microcontroller. For this project, the *Arduino* board is selected as the system microcontroller as it is simple, low cost and very popular [21]. The requirements for the development of the proposed semi-automated road painting machine are acquired from the literature review. Based on several patented designs, the conceptual designs for the road lane painting system are proposed in accordance to the *Product Design Specifications* (PDS) or requirements for the project that is presented as shown in Table 1.

Table 1: Product Design Specifications (PDS)

Product Design Specifications	Description
Main prime mover	Electric bicycle
Maximum load (weight)	50 kg (excluding the weight of a human operator and electric bicycle)
Maximum speed	Estimated around 10 km/h
Design	Aesthetics in mobile design to include compact design
Economic factor	Low cost
Weight	Light, compact and manageable
Power source	Rechargeable lithium-ion batteries
Design	Simple and easy to fabricate
Material	Liquid white paint
Type of line	Continuous line with interval gap
Quality of line	Sharp and nice
Semi-automatic operation	Semi-automatic operation using <i>Arduino</i> microcontroller system
Rear camera and LCD screen	Observe real-time painting task
Safety lamp	Enable good visibility of the system during operation, obviously for safety reason

The painting system is the crux of the prototype. It consists of the mobile plate form and the painting accessories that can be later connected the electric bicycle through an arm connector. The design frame work is an important step to describe the design process and thus it will be explained to cover the followings: functional analysis, morphological chart, conceptual ideas, evaluation matrix, further development step and CAD model. Functional analysis is an important step for analysing the core functions of a system. In developing the system, only the mechanical functions of the system is being considered. Other aspect such as the materials, dimensions, and electronic components are initially omitted from the design so as not to constrain the creativity of the conceptual design of a system. The system for this project is developed by incorporating some of the different general functions that are found on existing products and via patent search of product design specifications mentioned in the literature reviews. There are five sub-systems that are necessary to ensure the proposed semi-automated road lane painting robot to perform its desired painting task effectively. If one of these parts is not available or missing, then the whole machine would not work well which are the driver mechanism, mobile platform, container, paint mechanism and paint template. A morphological chart is a visual way to obtain possible new ideas by capturing the function of each sub-system and then combining them into one workable function. Table 2 shows a morphological chart related to producing a number of conceptual design ideas by selecting each section number of the sub-system component to be assembled into a system.

Table 2: Morphological chart

FUNCTIONAL ANALYSIS	1	2	3	4	5
DRIVER MECHANISM					
PLATFORM					
CLEANING ROAD MECHANISM					
HEATING MECHANISM					
PAINTING MECHANISM					
PAINT TEMPLATE					

From the morphology chart, options component for each functional analysis criterion are considered to produce initial ideas of varied proposed designs particular emphasis on the design of the mobile platform with its painting accessories. Each of the designs are analysed with respect to the product design specifications. Five conceptual ideas are produced. The conceptual ideas are then evaluated using an evaluation matrix based on specific design criteria which each of them is specified with a certain weightage as shown in Table 3. The conceptual idea that scores the highest will then be selected as the ‘ideal’ or ‘optimised’ design and chosen as the final design to be further developed. The mark is valued based on scores 1 until 5 (worst to best). From Table 3, it is apparent that Concept Idea 3 scores the highest point which is 340 compared to that of the others. Therefore, Concept Idea 3 is chosen to be further developed and refined as the final design. Further development is the stage to describe in greater details of the selected conceptual design idea (Concept Idea 3) and the modification done to perceive a workable logical system. It is noted that as the centre line available on the roads are consist of either single or double line patterns the actual proposed painting system for this work needs to be modify appropriately to cater for both line patterns while maintaining the concept of gravitational flow of Concept Idea 3. As such, the required modification is to increase the number of gate from one gate to three. For ease of fabrication, the container of the paint is constructed in the form of a box. All the three gates were designed to actuate using solenoid actuators. The concept of the painting mechanism device for this work is shown in Figure 2.

Table 3: Evaluation matrix

NO.	SELECTION CRITERIA	WEIGH TAGE	RATING*					SCORING				
			1	2	3	4	5	1	2	3	4	5
1.	Economical cost	10	4	3	4	3	2	40	30	40	30	20
2.	Easy to fabricate	10	5	3	4	3	1	50	30	40	30	10
3.	Material accessibility	10	4	4	4	3	2	40	40	40	30	20
4.	Aesthetics look	5	2	4	2	3	4	10	20	10	15	20
5.	Safe to use	20	4	4	4	4	3	80	80	80	80	60
6.	User friendly	5	4	4	4	3	4	20	20	20	15	20
7.	Sharp and nice line	20	2	3	3	4	3	40	60	60	80	60
8.	Power consumption	5	4	3	4	3	2	20	15	20	15	10
9.	Maintenance	5	3	3	3	2	2	15	15	15	10	10
10.	Various line type	10	3	3	3	3	3	15	15	15	15	15
TOTAL SCORING								330	325	340	320	245

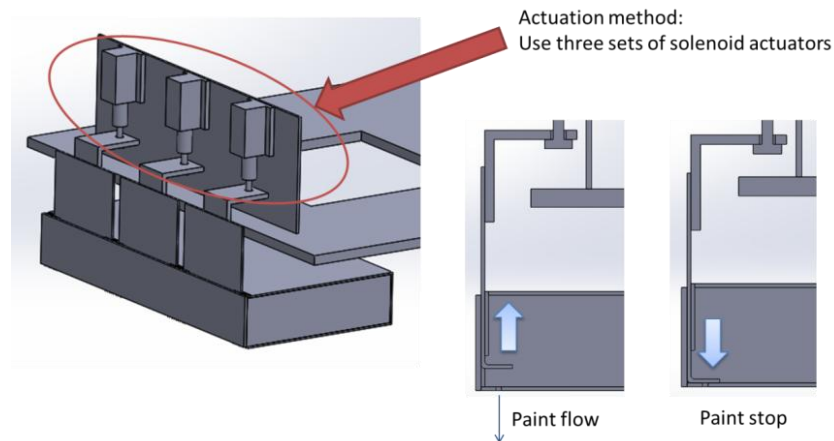

Figure 2: Painting mechanism device

The paint mechanism is to be mounted at the rear of the mobile platform. To transfer the paint from the paint tank to the paint discharge compartment, a heat resistance hose equipped with a solenoid-controlled valve was used as a connector for the flow of paint from the paint tank to paint discharge compartment. A minicamp heating burner was used as the paint container heating module. For stability purpose, the control box containing the microcontroller and other electronic devices were placed on a mobile platform rather mounting them onto the back of the prime mover, i.e., an electric bicycle. The platform was placed at the back to ensure the its path is in-line with that of the electric bicycle. The top view of all the painting accessories on the mobile platform is shown in Figure 3. The developed CAD model of the final proposed design using SolidWorks software is shown in Figure 4. By producing the model, some limitations of the design can be assessed pertaining to space, functionality, overlapping components that might cause collision between components and others.

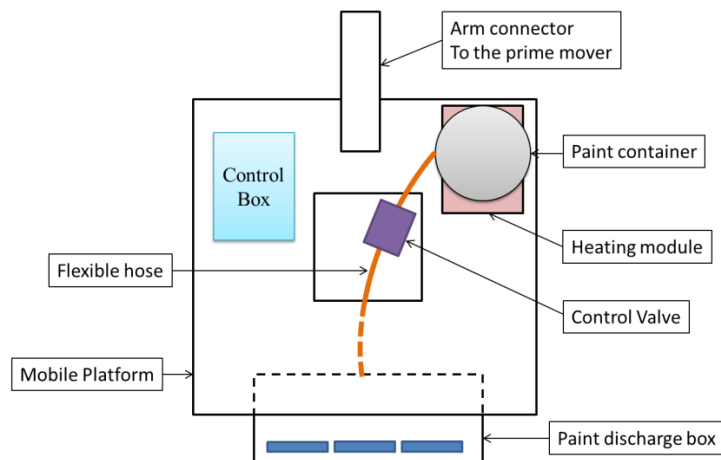

Figure 3: Top view of all the painting accessories position on the mobile platform

In the model, an additional safe lamp is added at centre of the design between the prime mover and painting system. This added feature is to ensure the safety of public safety surroundings by alarming the people that the painting operation is being performed. The painting system consists of a tank to store paint and a painting device to discharge the paint onto the road surface. The tank is heated with a burner to maintain the paint in molten state during the painting process.

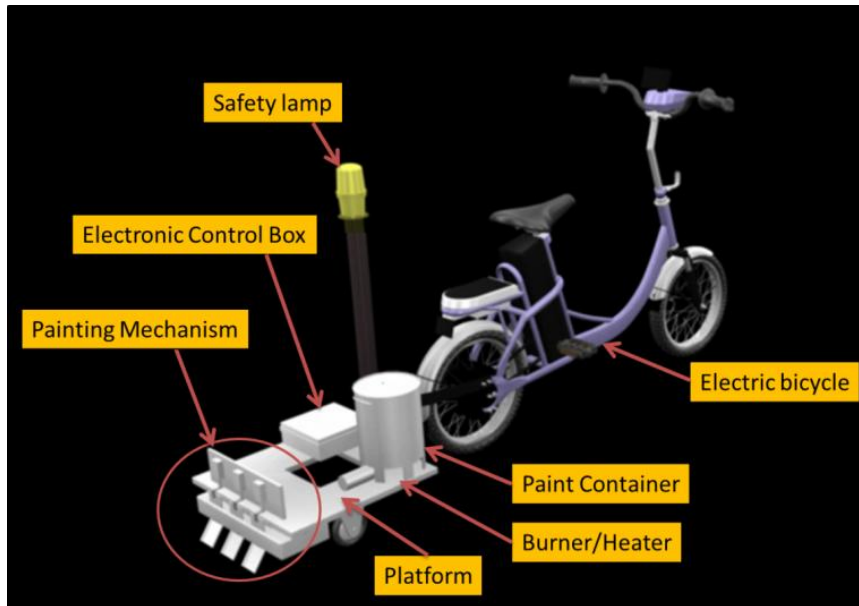

Figure 4: CAD model of the proposed final design

The flow of the paint is controlled by a solenoid valve. When the solenoid valve is opened, the paint will flow into the paint compartment. When the gate outlet of the paint box is opened, the paint will be discharged onto the road. Figure 5 shows the operations of the proposed painting process.

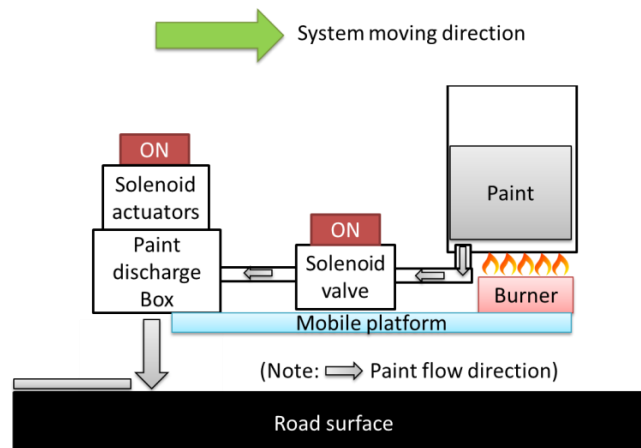

Figure 5: The proposed painting process

All of the devices involved in the system is connected to a 12 V DC power supply except for the *Arduino* microcontroller which runs at 5 V. The *Arduino* is supplied with 9 V battery equipped with step-down voltage and voltage regulator to ensure input power supply of 5 V to all the output channels. A bluetooth module will be used to receive signals from an application (app) inside a smartphone as the remote controller of the system. Figure 6 shows the schematic of the electrical circuit for the system.

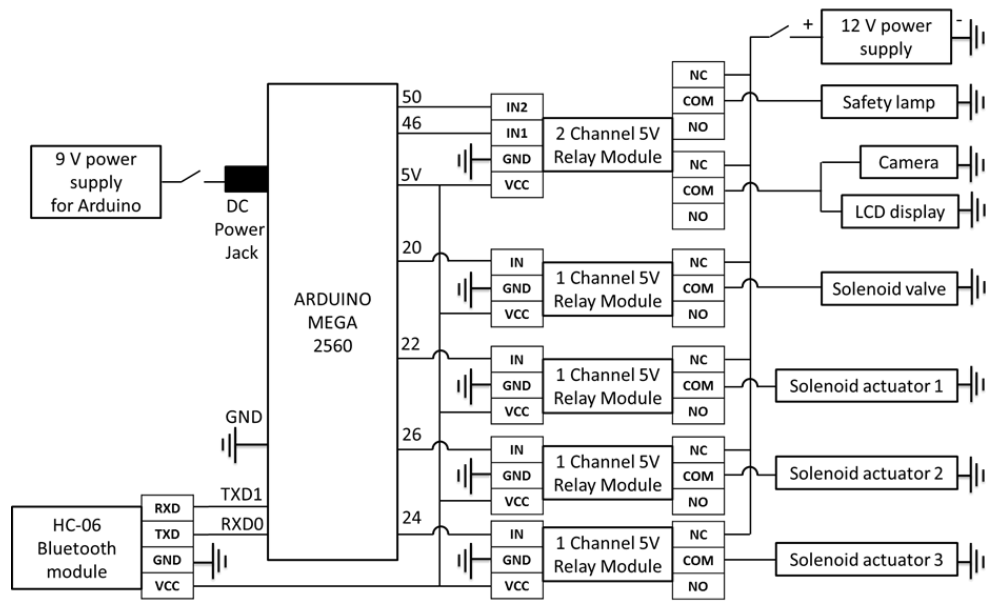

Figure 6: Schematic of the electrical circuit

4.0 SYSTEM INTEGRATION

System integration is a process of connecting different components forming one large functioning system. In this project, the complete system integration will be about the interlinking of all hardware and software for the development of a prototype intended for painting variation of single or double lines on surface of roads. Special emphasis will be given on the fabrication of the painting mechanism with appropriate electrical/electronic circuit assemblage. Extra features of the developed system are first presented. Next the fabrication of the painting mechanism and mobile platform, and arm connector are elaborated. Then the electrical/electronic circuitry (electrical wiring connections) for all devices including *Arduino* microcontroller interfacing with an application (app) built for Android smartphone as the remote controller will be described. A number of photograph images related to the development of the proposed system realised and developed in the laboratory setting are presented. On completing the fabrication, the prototype will be tested to evaluate its performance. Problems encountered during the experimental testing are also discussed in this section.

4.1 Mechanical Parts

A yellow safety beacon lamp was used for the project. It is typically the one used in construction sites and on top of heavy moving vehicles such as truck and tankers. The lamp is used to provide warning signals to passing vehicles near to the site of operation. For high visibility, the lamp is placed at a height of 1.5 m from the surface of the mobile platform using a supporting bracket. The placement of the safety lamp is shown in Figure 7 (a). The camera and LCD display comes in a set. The LCD display enables the operator to monitor closely the painting operation. The camera was mounted on top of the painting mechanism device, facing down towards the painting effective area as shown in Figure 7 (b). The LCD display is attached on the instrument casing of the bicycle's handle facing the operator/rider as shown in Figure 7 (c).

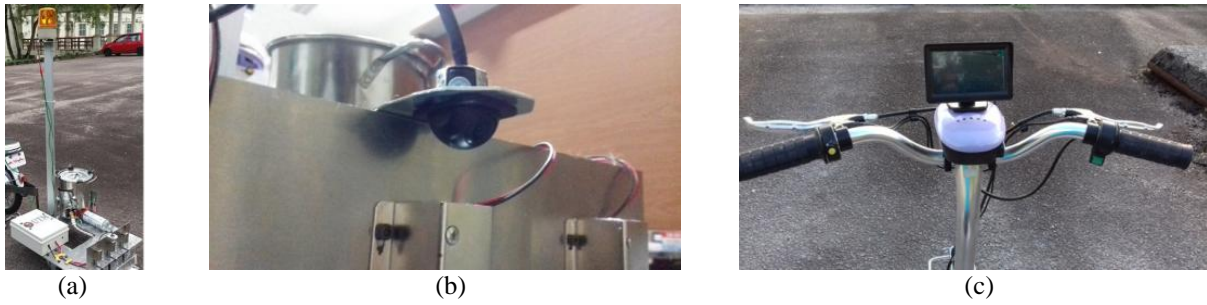

Figure 7: (a) Safety lamp mounted on the platform, (b) Camera mounted on top of the painting mechanism device and (c) LCD display is attached on the instrument casing of the bicycle's handle

The painting system as mentioned in the previous section was fabricated and is shown in Figure 8.

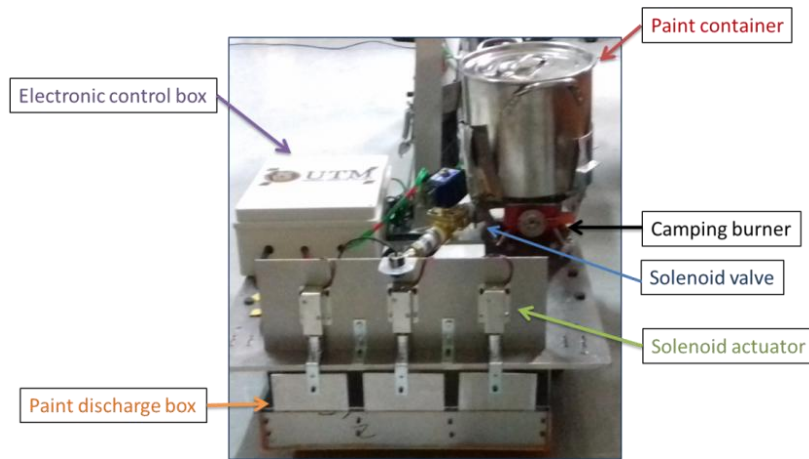

Figure 8: Fabricated painting system

The heating module used for the system is a mini camping burner that runs on butane gas and was purchased at a grocery store. As a safety precaution, an aluminium foil was wrapped around the paint container to isolate the fire beneath the paint container. The electronic control box was located on left side of the cart which serves to contain the main control system and stabilise the platform. The entire metal plate thickness is 2 mm except for the gate which is 1.5 mm and is made from 5083 aluminium alloy which is highly resistant to seawater and industrial chemicals [22]. The inside design of the paint discharge box is shown in Figure 9 (a). The gate of the paint discharge box was designed independently side by side sharing the same paint reservoir. The gate design was the same for all as shown in Figure 9 (b). The gate which is made from aluminium alloy plate was bent at 15 mm to produce a 90° angle plate. The outlet of the paint discharge box was located beneath the gate. Beneath the discharge box, was a three set of holes for the paint to flow out from each gate as shown in Figure 9 (c). In order to produce a sharp square line a template was designed and put at the bottom of the paint discharge box as shown in Figure 10.

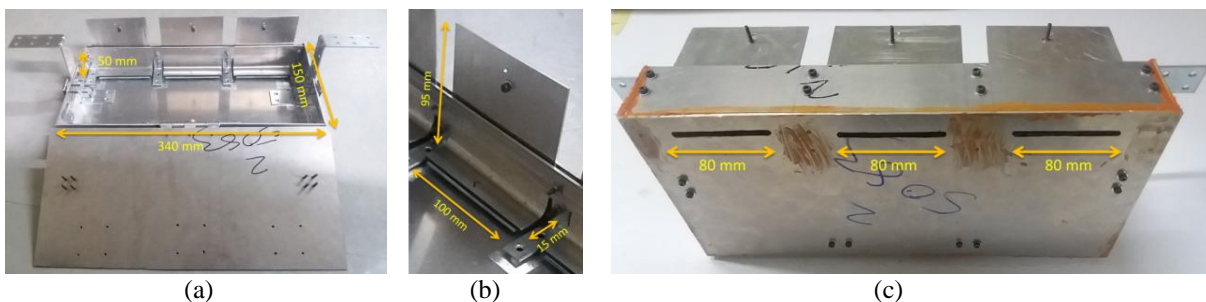

Figure 9: (a) Inside design of the paint discharge box, (b) Gate size specification and (c) Bottom view of the paint discharge box

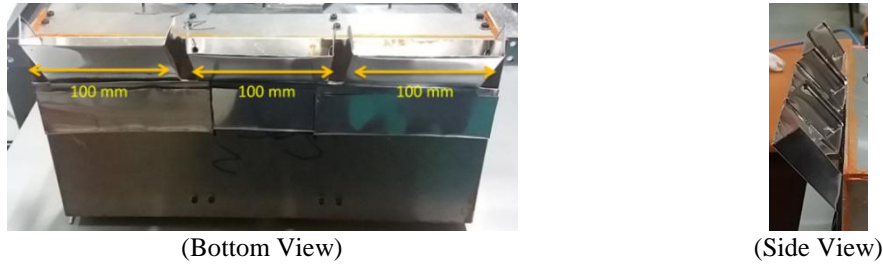

Figure 10: Template design for the paint discharge box

A template was made for each hole by using aluminium foil that was folded to have an opening of 100 mm at the bottom. The template also had a rectangular guided corner at the side to ensure the paint does not spill onto unwanted areas outside the target line painting area. The paint discharge box was then fixed at the bottom back of the mobile platform using the pre-fix L brackets installed at the side of the box. A set of actuators for each gate is then fixed on top of the mobile platform to pull a specific gate opens and release the gate downwards to close. Figure 11 shows the view when the gate slides upward.



Figure 11: Paint gate sliding up view

As seen in Figure 11, a pair of silicon plates was used to ensure the paint is completely sealed out from discharging paint material when the gate is closed. Silicon can withstand high temperature approximately 1000°C and, as such, the material is suitable to contain paint even if heated up to 300°C. Based on approximate total weight acting on the gate, the minimum force required for the gate to open and close properly is 2.4 N with a safety factor of 1.5 included in the calculation. A commercial 12 V DC solenoid actuator used for locking doors and drawers with pulling capability of about 3 N was used in the project.

The mobile platform was fabricated using mild steel. A square hole was roughly constructed in the middle of the platform to enable the possibility of connecting the paint container and paint discharge box with the means of piping, solenoid valve and flexible hose. For mobility of the platform, three wheels were attached to the bottom side of the platform. Two rear wheels that can only move in a one straight direction is fixed behind the painting discharge box, while the remaining one wheel act as a front wheel that can rotate freely in any direction. The position of the wheels was made so that the mobile platform can move in either straight or curve motion following the prime mover. Figure 12 (a) shows the mobile platform used in the project. The connection between the mobile platform and the electric bicycle was made by using a self-made arm connector consists of a welded item screwed to the rear frame of the electric bicycle and a plate with a hole fixed at the front of the mobile platform. The arm connector connection is shown in Figure 12 (b).



Figure 12: (a) The mobile platform used in the project, (b) Arm connector

4.2 Electrical and Electronics

All the electric and electronic circuitry functions of the system were basically controlled by the *Arduino* microcontroller. For this project, the *Arduino* Mega 2560 card was used. As the *Arduino* microcontroller can only handle 5 V inputs and output supply, a separate power supply of 12 V to activate the other integrated devices was connected with the *Arduino* using three sets of 5 V Single Channel Relay Module and one set of 5 V Two Channel Relay Module. This project used a HC-06 Bluetooth module to receive the incoming signal sent from a smartphone as the remote controller of the system. The electrical parts were interconnected through a schematic of electrical circuit as shown in Figure 6. The actual wiring of the circuit was done inside the electronic control box as shown in Figure 13.

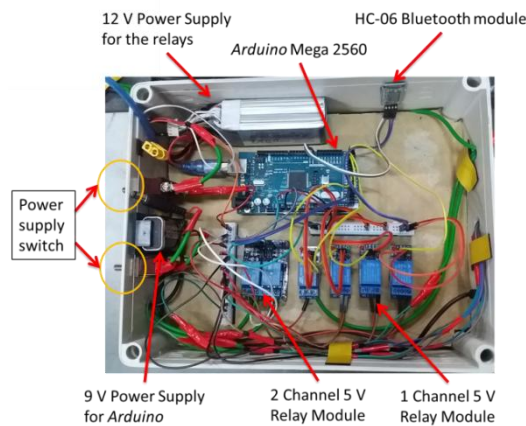

Figure 13: Wiring inside the electronic control box

4.3 Computer Programming and Application Software

The whole electronic system is designed to function only when both power supplies switches are turned on to avoid unnecessary wastage of electricity and burnt out while the system is in idle state. Upon switching on the system, the bluetooth module will start to function and can be connected to a remote controller design app using *MIT App Inventor 2* interface from a smartphone that will allow the *Arduino* to make decision of executing the desired operation needed by the user. The app's interface viewing screen that was built using the software consists of a number of touch buttons are as shown in Figure 14 (a). The built-up function of the app is as shown in Figure 14 (b).

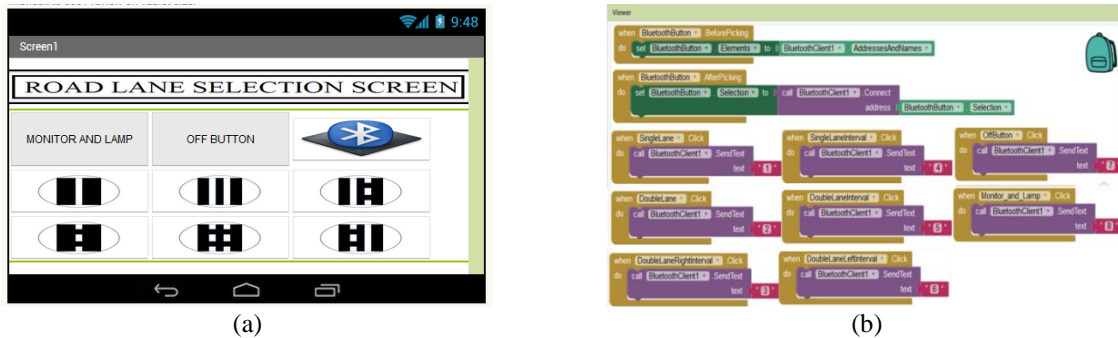

Figure 14: (a) Smartphone screen of the open app, (b) Built up function of the app

In Figure 14 (b), the first two rows of blocks represent the bluetooth connection function built for the bluetooth icon button. The first row function is to search and identify all available bluetooth receivers at the surroundings. The second row is for the selection command to establish the connection between the receiver and the transmitted signal from the app after a particular bluetooth receiver was selected. The remaining rows were programmed to send single digit signal to the bluetooth receiver when any other button than the bluetooth icon was touched. Each button has been assigned a specific single digit signal number from 1 to 8. These received signals by the bluetooth module was relayed to the *Arduino* for executing a desired command to actuate the appropriate actuators depending on the signal received. The *Arduino* on the other hand was programmed by using an open-source *Arduino* Software (IDE) which can be downloaded from the *Arduino* website. The coding was written in a way that upon receiving the signal from the bluetooth module, the execution of switching on and off the related devices triggers the desired operation. There are two main coding functions, 'if' and 'while' functions. The statements in those functions were the key of deciding the appropriate execution of task to be made. The 'if' function was used to execute a written program command once until a different signal is received. However, the 'while' function was used to execute the command in an infinite loop until a different signal is received. The general operation sequences for the devices are shown in Figure 15 (a) for the 'if' functions and Figure 15 (b) for the 'while' function.



Figure 15: (a) General operation sequence in the void loop for 'if' function that receives the signal (b) General operation sequence in the void loop for 'while' function that receives the signal

Whenever a new signal was received from the bluetooth module, the previous command will be overwritten with the new operation sequence for the new signal. However, there were exception in the coding the operation sequence, whereby once activated cannot be turned off with other signals except the off button signal which the related devices are the safety lamp, LCD display and camera to ensure the operation safety at all time. To stop the ongoing operation the 'if' function for off button will execute the shutdown of all the devices and delay the off sequence of safety items for 5 s. The written program was transferred to the *Arduino* board using a USB cable type A/B via PC. With the programming of the *Arduino* board completed, the whole system was assembled and later tested for its workability as explained in the succeeding sections.

5.0 TESTING AND EVALUATION

The working prototype was realised after all the assembly tasks have been carried out in relation to the integration of two important sections, i.e., the prime mover (an electric bicycle) and the mobile platform with the painting accessories mounted on top and bottom of the platform. Figure 16 shows the full assembly of the working prototype of the proposed on-the-road painting machine.



Figure 16: Full assembly of the working prototype

Before actual testing of the paint mechanism, water test was done on the system to test the painting system workability of any leaking. However, it was found out that the solenoid valve is not compatible with the design as water was flowing very slowly as the water pressure from the tank was insufficient. Therefore, there was a need to modify the system design by changing the solenoid valve into a normal valve. Figure 17 (a) shows the actual water testing on the solenoid valve. Water testing was done again, and the normal valve worked perfectly. Figure 18 (b) shows the water testing on a normal valve.



(a)



(b)

Figure 17: (a) Water testing of solenoid valve (b) Water testing of normal valve





Although the water flow is flowing smoothly, this new modified design does not give the operator the choice of controlling the paint quantity to flow into the container remotely. However, it serves the purpose of allowing the heated paint from the paint container to flow into the paint box before the painting operation took place. Last step before actual testing of the paint mechanism, the water-based white paint concentration should be prepared according to a suitable mixture. For the first test, the paint itself without any diluting mixture was utilized. The system was found to be clogged. Therefore, it is known that the system cannot be used with only the liquid paint itself. Several paint mixture was then prepared by diluting the paint with water to find the best suitable mixture to test the system workability. A mixture of paint and water example for 60% dilute paint preparation procedure is as shown in Figure 18.



Figure 18: Mixture of 60% diluted paint

The first jug containing the water about 300 ml was measured using a measurement container and poured into a pail. Subsequently, another liquid paint was measured to be at about 200 ml and poured into the pail. The mixture was mixed well by stirring. Next the evaluation of suitable painting mixture on the proposed painting mechanism was done by using paint dilute mixture of 60%, 50%, 30% and 10% for painting a single straight lane pattern on actual road. The results are shown in Table 4.

Table 4: Single straight line paint result with different type of paint dilute percentage







Paint dilute percentage	Single Lane	Average Line Width (mm)	Consistency	Smear
60%		113	No	Yes
50%		107	No	Yes
30%		95	Yes	No
10%		82	No	No

From Table 4, for 60% diluted paint, the painted line colour was found to be thin and with larger smearing. For 10% diluted paint, no smearing is observed. However, the inconsistency in the line width produce was likely due to paint mixture to be quite viscous (thick and slow flowing) that cannot cater the minimal speed of the electrical bicycle. The nearest line width results compared with JKR standard line width of 100 mm are 50% and 30% diluted paint result. However, for 50% diluted paint there is an uncertainty of smearing occurrence at random places which makes 30% diluted paint to be the best with good consistency of line width and has no smear. Therefore, 30% diluted paint mixture will be used next to test the performance of the proposed painting mechanism for other possible straight single and double lane patterns.

Table 5 shows the results for different line pattern for 30% diluted paint. From the table, the proposed painting mechanism was able to produce a straight line for single lane pattern. However, the produced painted line was still not as sharp as the road line that exists on normal daily road. This is because there is no mechanism to evenly distribute the line into a constant width such as using brushes or roller in a pre-confined space. The average line width produced was measured to be approximately 100 mm according to the standard for Malaysia road for urban area. Further observation was made on other line patterns, there are bits of paint residue observed between the line with intervals; these can be seen in all interval line cases for both single and double line patterns. This is due to the fact that some paint residue left on the template had dripped onto the road when the paint gate closes. Therefore,

further detail design on the template needs to be done to ensure a sharp and smooth line can be produced.

Table 5: Different line pattern results for 30% diluted paint

Lane Type	Result	Observation
Single Line		Almost a sharp single line was produced
Single Interval Line		Small white drag spots between the interval line were detected
Double Line		Double line with inconsistent width was produced
Double Interval Line		There exists small white drag spots between the interval line
Single line on the left and single interval line on the right		Small white drag spot exists for the interval line pattern on the right
Single interval line on the left and single line on the right		Small white drag spot exists for the interval line pattern on the left

For the double line pattern, the drawn line pattern was found to be more crude compared to the single line pattern. This might be due to the different paint flow rate going out of the two gates caused by a sudden drop in pressure compared to situation when only one gate is open. Other factor may be due to vibration caused by the unevenness of the road when the mobile platform is moving. The paint box might ‘wobble’ while moving that causes the unsteady flow of the paint through the right and left gate channels of the painting mechanism module during the painting operation. One of the ways to solve the problem is by separating the paint reservoir for each gate channel. An issue related to the painting box discharge design was noted, it was not easy to determine the remaining volume of paint in the box. The operation sometimes will stop half way because no more paint is in the paint discharge box. Thus, an indicator to determine the volume level of the paint in the discharge box is recommended. An additional finding of the study is that the solenoid valve is not appropriate to be used in the system, thus the paint flow from the paint container cannot be adequately controlled. Therefore, a different control valve than a solenoid valve is recommended which can withstand the heated paint.

A comparison study with Ali *et al.* [2] work was also done. The producing lane marks quality was not clearly stated in [2], however, it is noted that the proposed semi-automatic on-the-road painting in this study is superior in producing different line patterns (single and double) not just restricted to a single straight continuous line. Nevertheless, the mentioned drawback of the system in the preceding paragraph need to be rectify for better performance of the system. Similarity in opinion of the hitch in utilizing an electrical bicycle as the prime mover is agreed. Whereby, it was not easy to operate the operation using an electric bicycle to move in a straight line as it is not that stable when it moves at very slow speed. Both legs need to be used to balance the bicycle will moving forward. Stable condition can be achieved by riding the bicycle at faster speed; however a poorer paint outcome was noted. As a countermeasure, the bicycle should have an additional stabilizing mechanism for example an extra one or two wheels/tire just like the training wheel attached for a kid bicycle. Other similarity issues, was the speed of the bicycle which is difficult to control to produce the same speed for each operation. The speed is dependent on how much the ‘throttle’ of the bicycle is being turn clockwise by

the operator. If the throttle was turned too little, the bicycle will become unstable and need to be supported by the operator legs. For the opposite case, for high speed by turning the throttle too much the paint quality will become poor as the paint will not be able to discharge evenly, paint drag and stretching occurrence is unavoidable and the paint will not be able to cover the desired paint effective area on the road. In other words, the paint mark will be quite insignificant and show poor quality line painting on the road surface. Thus, there is a need to ensure the speed is constant for better result. At the early stage of undiluted liquid test of the proposed system, paint clogging occurred. However, it was easily dealt by heating up the paint container for a small period of time. Therefore, the proposed system in this study has an advantage of solving the clogging problem faced by Jali [18] and Ali *et al.* [2] that only use an air compressor connected the paint tank to pressurise the paint to flow out of the spray gun that needs the painting operation to be done in a fast manner before the paint start to dry and clog the system. With findings related to the result of the painted line is obvious that more works can be done to produce better outcomes and results. Hence, a list of recommendations for future works is presented.

- a) Solve the template design issue to produce sharp edge for the lane patterns.
- b) Design a novel control valve to handle the transfer and flow of the heated paint.
- c) Try other type of prime mover/s (drive mechanisms) such as motorcycle and four wheeled systems (based on electric, internal combustion engine or hybrid drives) for higher power and better stability so that a more complex and heavy duty applications can be carried out.

6.0 CONCLUSION

A practical road lane painting mechanism attached to an electrical driven vehicle had been designed and developed. The prototype was tested based on mechatronic approach in which the elements of mechanical, electrical/electronic and computer control were completely integrated into the system. The painting machine was capable to produce different crude pattern lines in the middle of the road (single or double lines) which can be continuous or interval patterns based on the written algorithms inside microcontroller and is remotely controlled by the operator using a built smartphone app. The prototype performance was tested with white liquid paint with different diluted mixture to acquire the most suitable mixture for further testing. It is known that the best mixture was when the paint was mixed with 30% water compared to 10%, 50% and 60%. A number of modifications were made, particularly in the physical design and fabrication of the mechanical parts to enhance the performance. The heat assisted paint system prevents the paint from clogging and improves the paint flow in the system. Further works need to be done to improve the quality of the lines produced.

ACKNOWLEDGEMENTS

The authors are grateful to the Universiti Teknologi Malaysia (UTM) and Ministry of Higher Education (MOHE) for providing the financial and technical support. This work is supported through a Research University Grant, Vote No.: 04H72.

REFERENCES

1. Abrams, S. 2013, *The Unseen History of Our Roads*, <http://www.roadandtrack.com/car-culture/a4447/the-road-ahead-road-evolution/>. Accessed 2 May 2017.
2. Ali, M. A., Mailah, M., and Tang H.H, 2014, Autonomous Robotic System for On-the-Road Marks Painting, 14th International Conference on Robotics, Control and Manufacturing Technology (ROCOM '14), Kuala Lumpur.
3. Woo, S., Hong, D., Lee, W.C., Chung, J.H. and Kim, T.H., 2008. A robotic system for road lane painting. *Automation in Construction*, 17(2), 122-129.

4. Kotani, S., Mori, H., Shigihara, S. and Matsumuro, Y., 1994. May. Development of a lane mark drawing robot. In *Industrial Electronics, 1994. Symposium Proceedings, ISIE'94., 1994 IEEE International Symposium on* (pp. 320-325). IEEE.
5. Teakway Industrial Sdn Bhd 2011, *Road Line Machine*, <http://www.teakway.com.my/roadline-machine.htm>. Accessed 13 May 2017.
6. R.S. Machineries Sdn Bhd 2003, *Roadline Marking Machines*, <http://www.thersgroup.com.my/prod01.htm> 13 May 2017.
7. *DY-HPT Road Marking Machine Sent to Malaysia*, 2011. <http://www.dyroad.com/news/59-dy-hpt-road-marking-machine-sent-to-malaysia.html>. Accessed 15 May 2017.
8. City of Edmonton, 2012. *Design and Construction Standards: Marking Pavements Guidelines*. Edmonton.
9. Road Safety Markings Association Department, 2010. *Top Marks: A Guide To The Road Marking Industry in UK*, UK.
10. Department of Transportation and Main Roads, 2013. *Guideline Pavements Marking 2013, Part D: Materials and Equipments*. Queensland, <http://www.tmr.qld.gov.au/business-industry/Technical-standards-publications.aspx>. Accessed 1 June 2015.
11. Witt A., Smith R. and Visser A., 2000. Durability and Cost Effectiveness of Road Marking Paint, *South African Transport Conference*, South Africa.
12. Public Work Department Malaysia, 1985. *Manual on Traffic Control Device: Road Marking and Dileanation*, Kuala Lumpur: Road Branch Public Works Department Malaysia.
13. Miller J. D., 1962. *United States Patent No. US3059574*, Beall Hall, McConnell AFB, Kans: United States Patents Office.
14. Southey Jr. S. J., 1929. *United States Patent No. US1738738*, Cleveland, Ohio: United States Patents Office
15. Selma P., 1953. *United States Patent No. US2751618*, Jamaica, N.Y.: United States Patents Office.
16. Derek A. F., 1981. *United States Patent No. US4269328*, British Colombia, Canada: United States Patents Office.
17. Hobe Sr. E. T., 1950. *United States Patent No. US2528657*, Mich: United States Patents Office.
18. Jali, M.K.M., 2016. *Mechatronic Design and Development of a Semi- Automated on-the-road Painting Machine*.
19. Seyyed K., 2005. *Engineering Design Process*. California, Solectron Corporation.
20. John I., 2004. *PIC Microcontroller Project Book 2*, New York, NY, USA: McGraw-Hill, Inc.
21. Simon M., 2013. *30 Arduino Projects for the Evil Genius*, Second edition, United States of America: McGraw-Hill Education.

22. Tsangaraki-Kaplanoglou, I., Theohari, S., Dimogerontakis, T., Wang, Y.M., Kuo, H.H.H. and Kia, S., 2006. Effect of alloy types on the anodizing process of aluminum. *Surface and Coatings Technology*, 200(8), 2634-2641.